

BIOBOX

Experiments Critical Design Review

May 28th, 1991

ESTEC, Noordwijk, Nederlands

BIOBOX on BION 10 Satellite

"PHOTON" SPACECRAFT

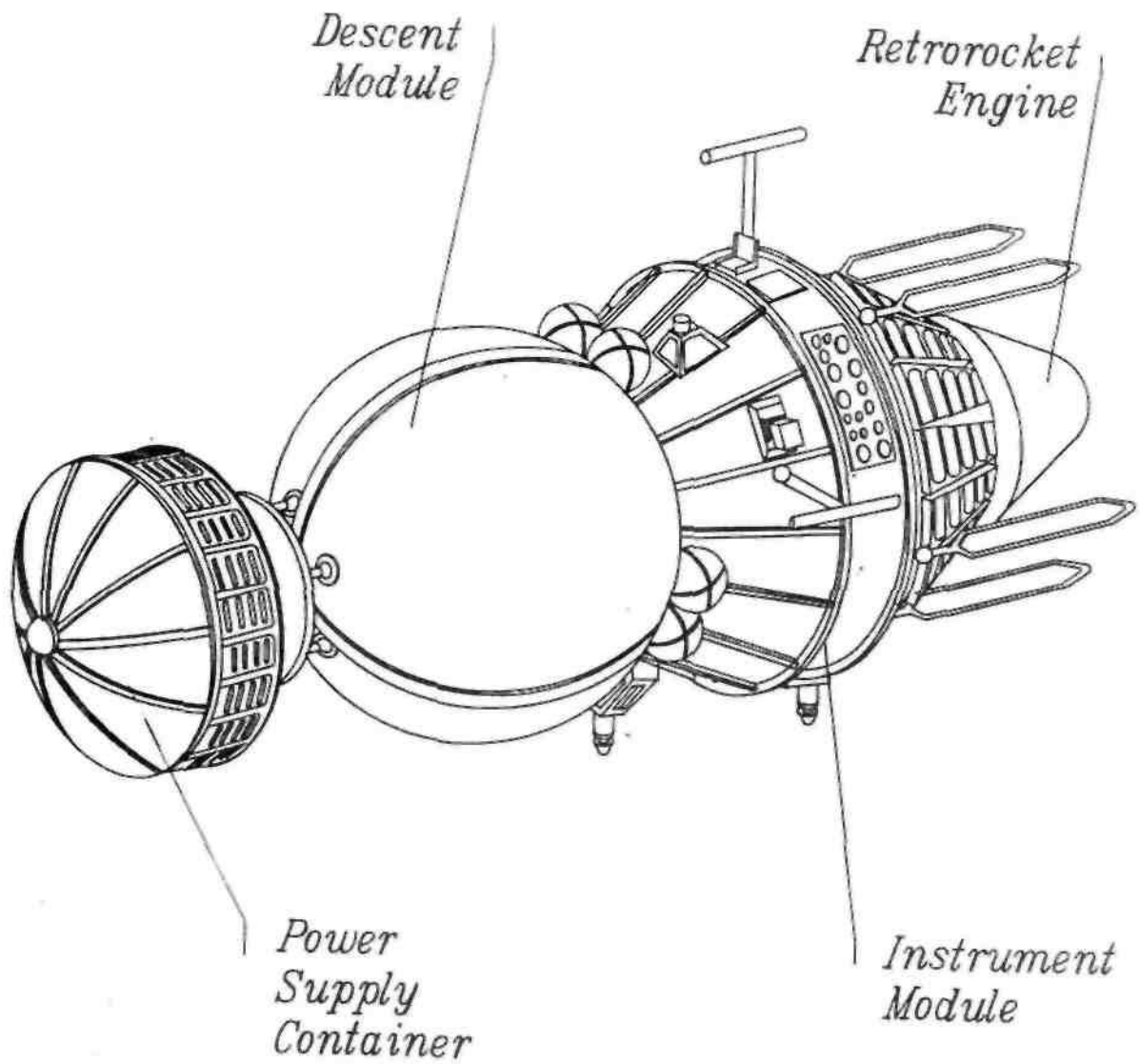

BION 10

Mission Time : 14 days

Launch Date : September 1st, 1992

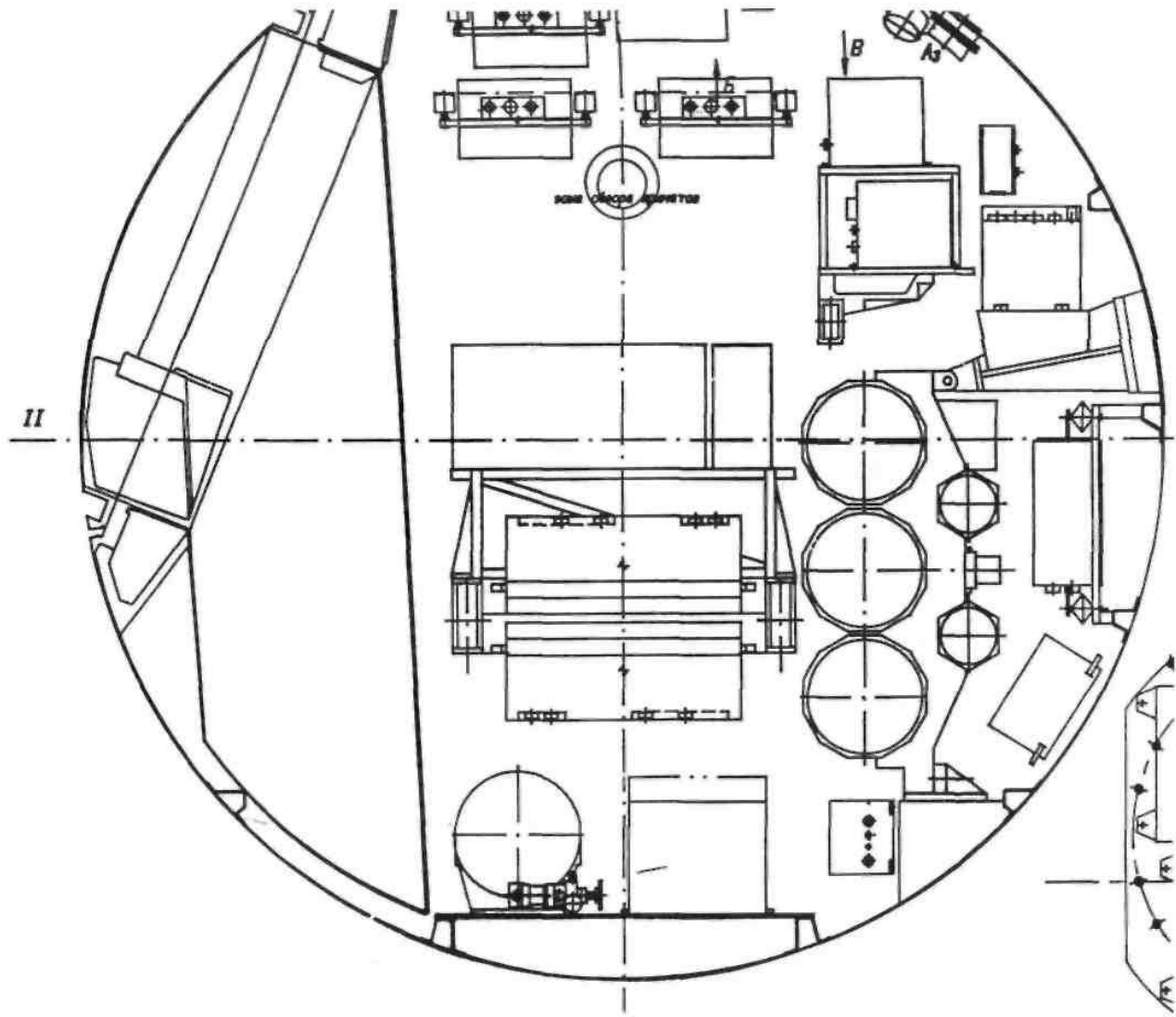

BION-10 Spacecraft

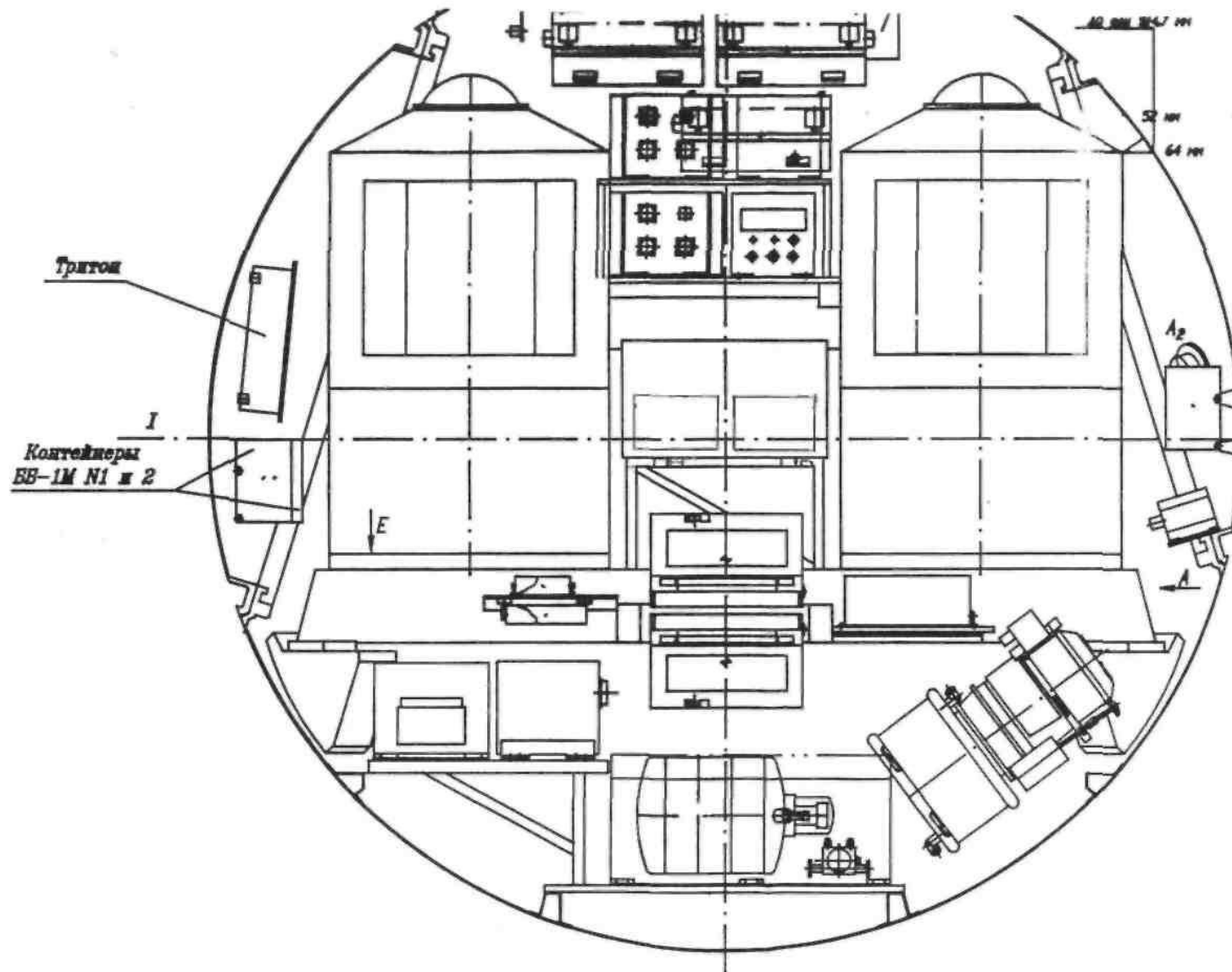

BION-10 Spacecraft

BIOBOX Project Overview

BIOBOX Study Team Responsibilities

Company	Responsibility
Dornier (DO) (Germany) Prime Contractor	<ul style="list-style-type: none">- Study Management- System Engineering- System Concept- Thermal Analysis- Software- Operations- Interfaces- Battery Unit- Product Assurance, Safety- Experiment Container Ie (EC Ie)
Kayser Italia (KI) (Italy) Subcontractor	<ul style="list-style-type: none">- Data nad Control Electronics- Power Electronics- Electronics Housing- EGSE- Inputs to PA, Safety
Verhaert Design Development (VDD) (Belgium) Subcontractor	<ul style="list-style-type: none">- Mechanical Subsystem* Incubator* Experiment Platform* Interface Plate- Mechanical Analysis- MGSE- Inputs to PA, Safety

Carrar (CA)
(France)
Subcontractor

- 1g Centrifuge Modifications
- Locking Subsystem
- Centrifuge Control Electronics
- Centrifuge Power Electronics
- Inputs to PA, Safety

Centrum voor Constructie en
Mechatronica (CCM)
(Netherlands) Subcontractor

- Switch and Control Box
- EGSE
- Inputs to PA, Safety
- CIS electronics
- dummy experiments

BIOBOX Schedule

BIOBOX Critical Design Review	June 91
int. Acceptance Reviews	Oct.-Dec. 91
Verification Tests	Jan.-Feb. 91
Flight Acceptance Reviews	March 91
H/W Delivery	March 91
Functional Tests (Samara, Plesetsk)	Mar.-May 91
Mission Sequence Test	June 91
Launch Campaign	Aug.-Sep. 91
Post Flight Review	October 91

BIOBOX Model Philosophy

Qualification Model

- 1 Incubator Facility QM
- 2 Battery Units BAT-Q1, BAT-Q2
- 1 set EGSE EGSE-Q
- 1 set MGSE MGSE-Q

Flight Model

- 1 Incubator Unit FM
- 2 Battery Units BAT-F1, BAT-F2
- 1 set EGSE EGSE-F
- 1 set MGSE MGSE-F
- 1 Hoisting Tool

Flight Spare

- 1 Incubator Unit FS
- 1 set MGSE MGSE-S

Mass Dummy

- Incubator Unit Dummy

BIOBOX Facility Design

BIOBOX

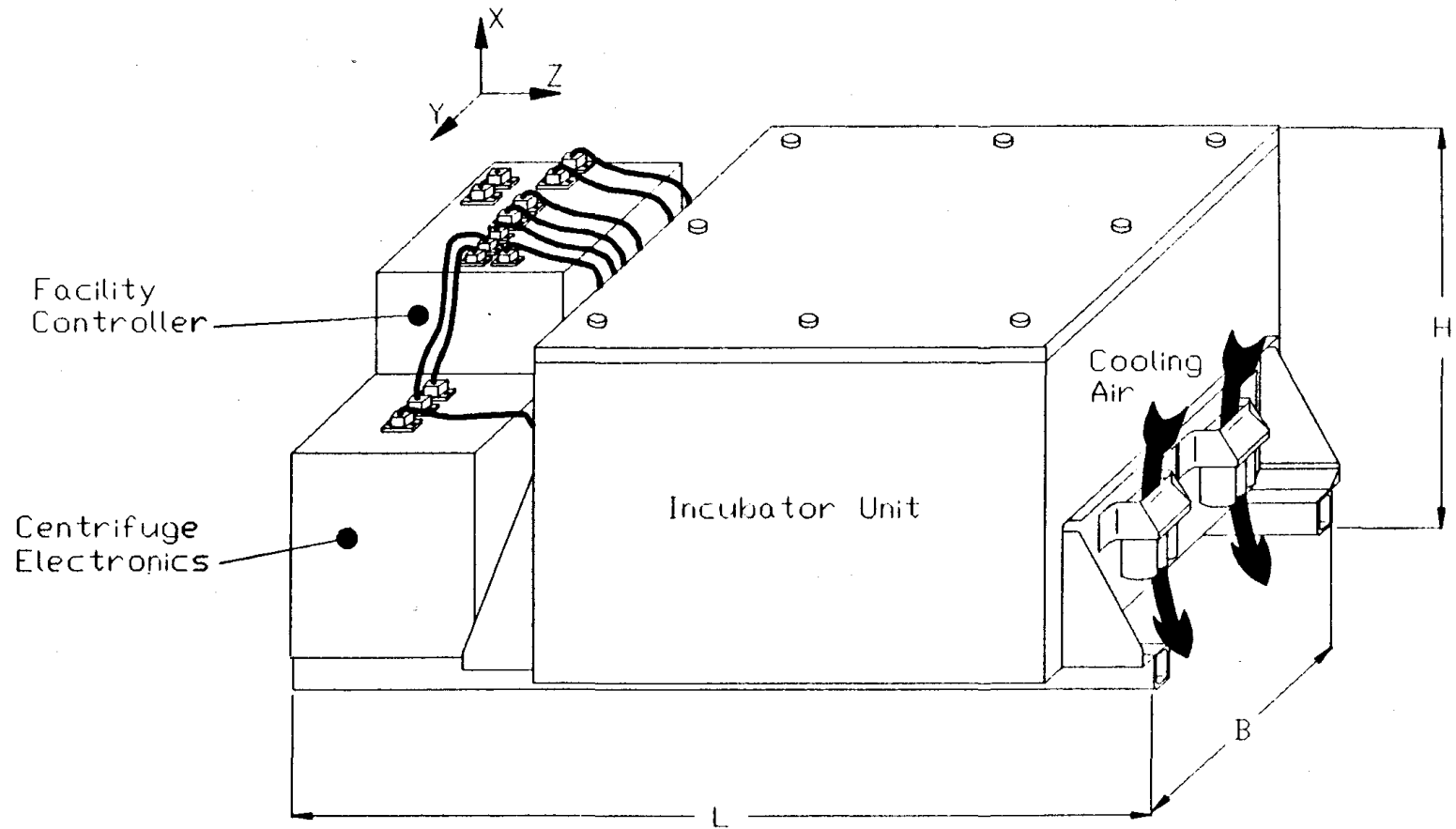

BIOBOX Facility Features

Dimensions 693 x 439 x 307 mm³ (L x W x H)

Weight 44 kg

Usable Volume 23.4 l

SIDE VIEW - RIGHT

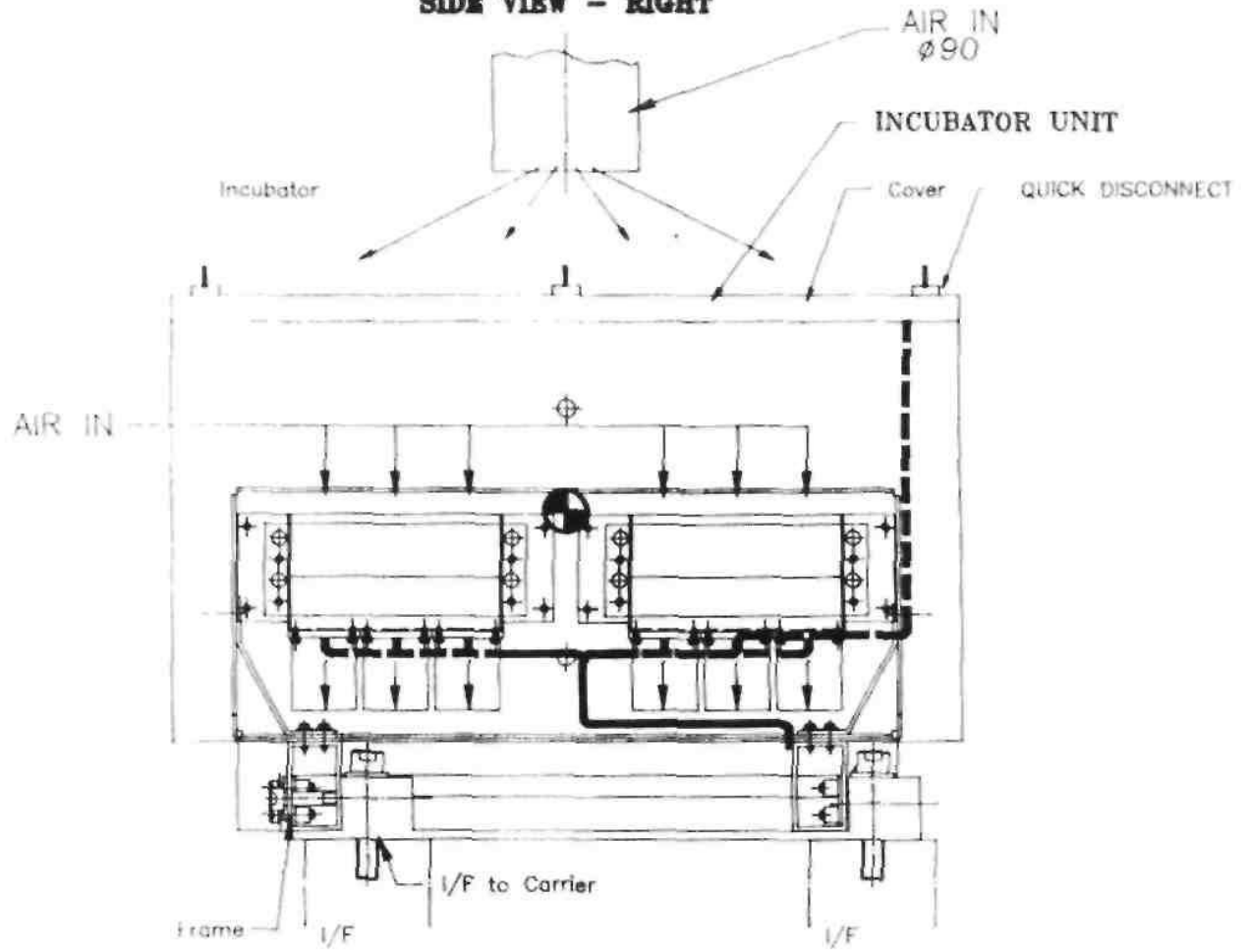

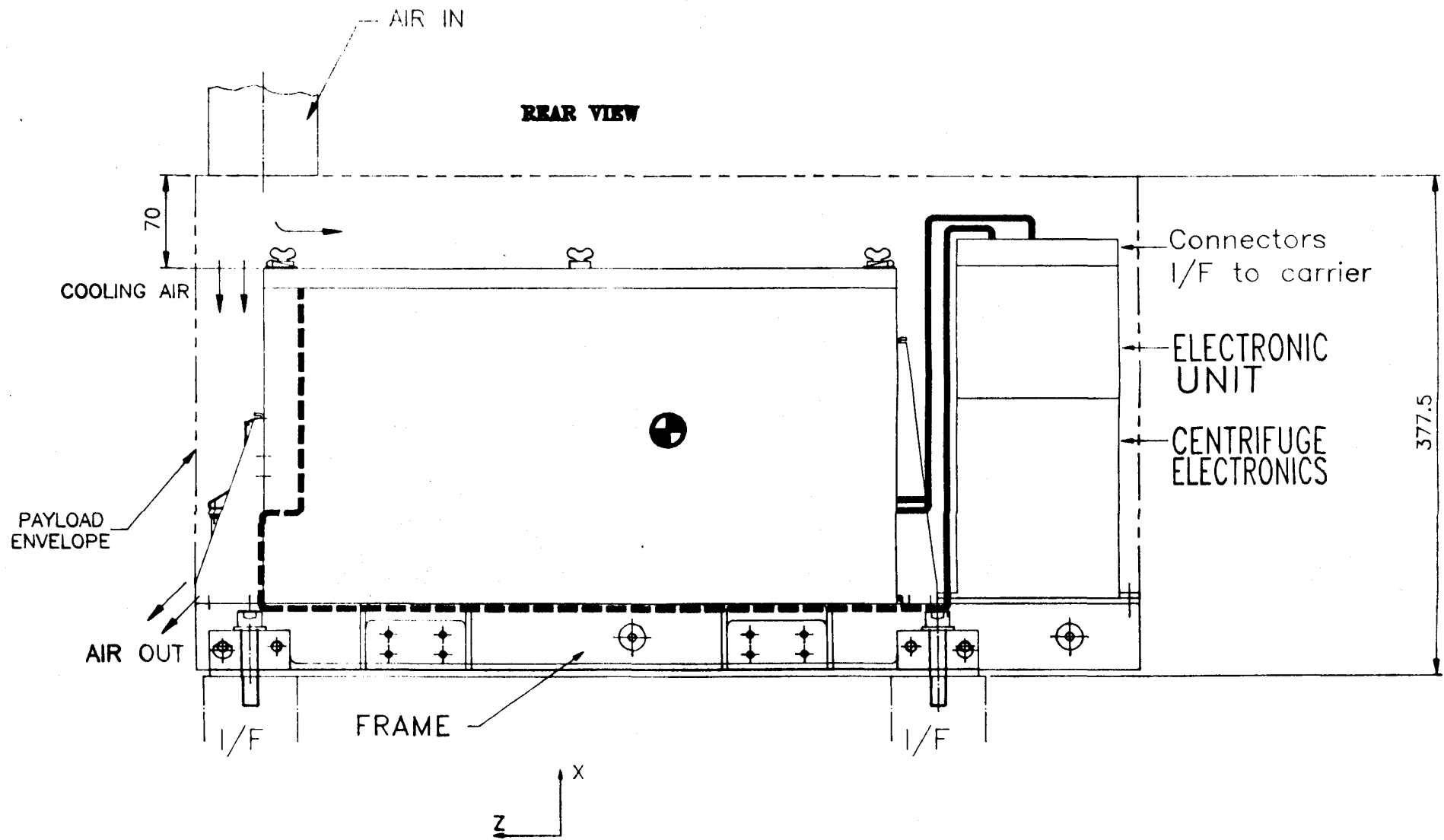

TOP VIEW

INCUBATOR UNIT

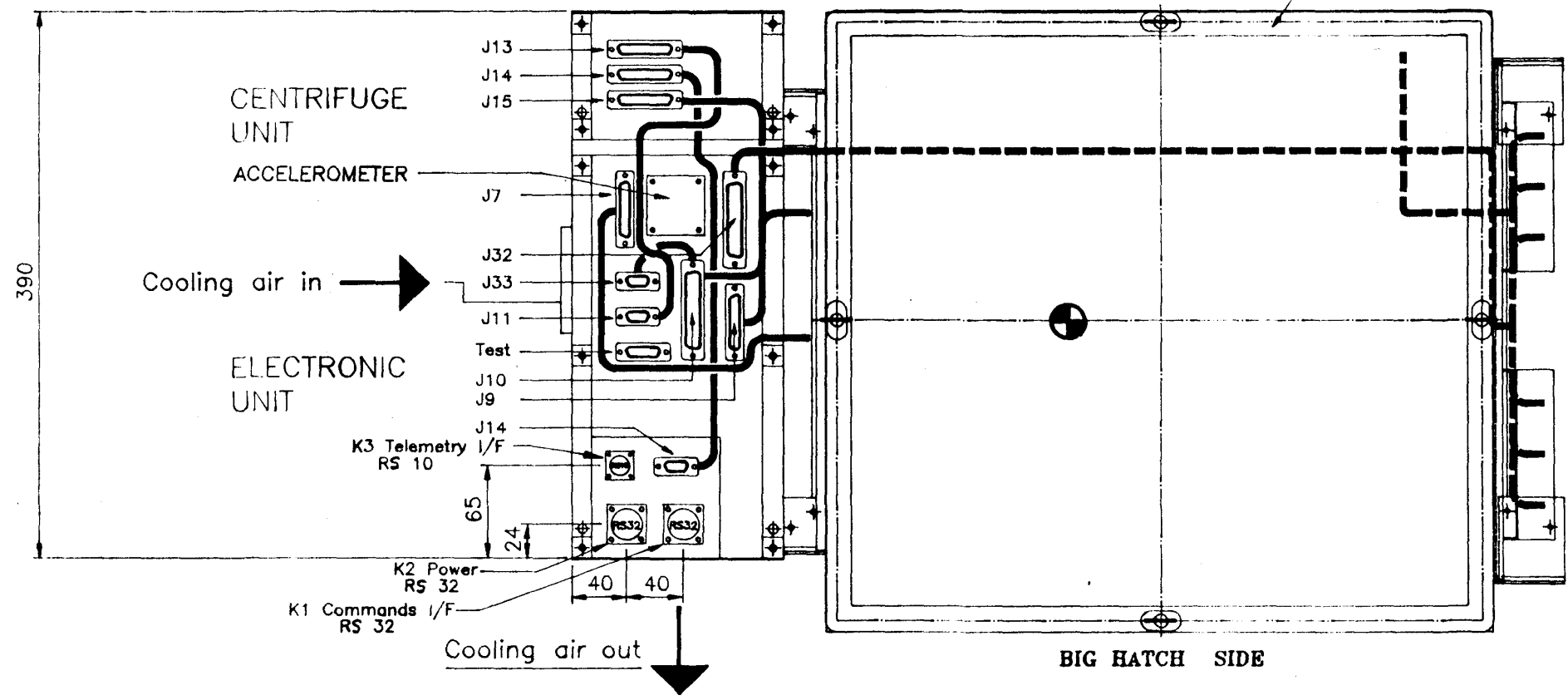

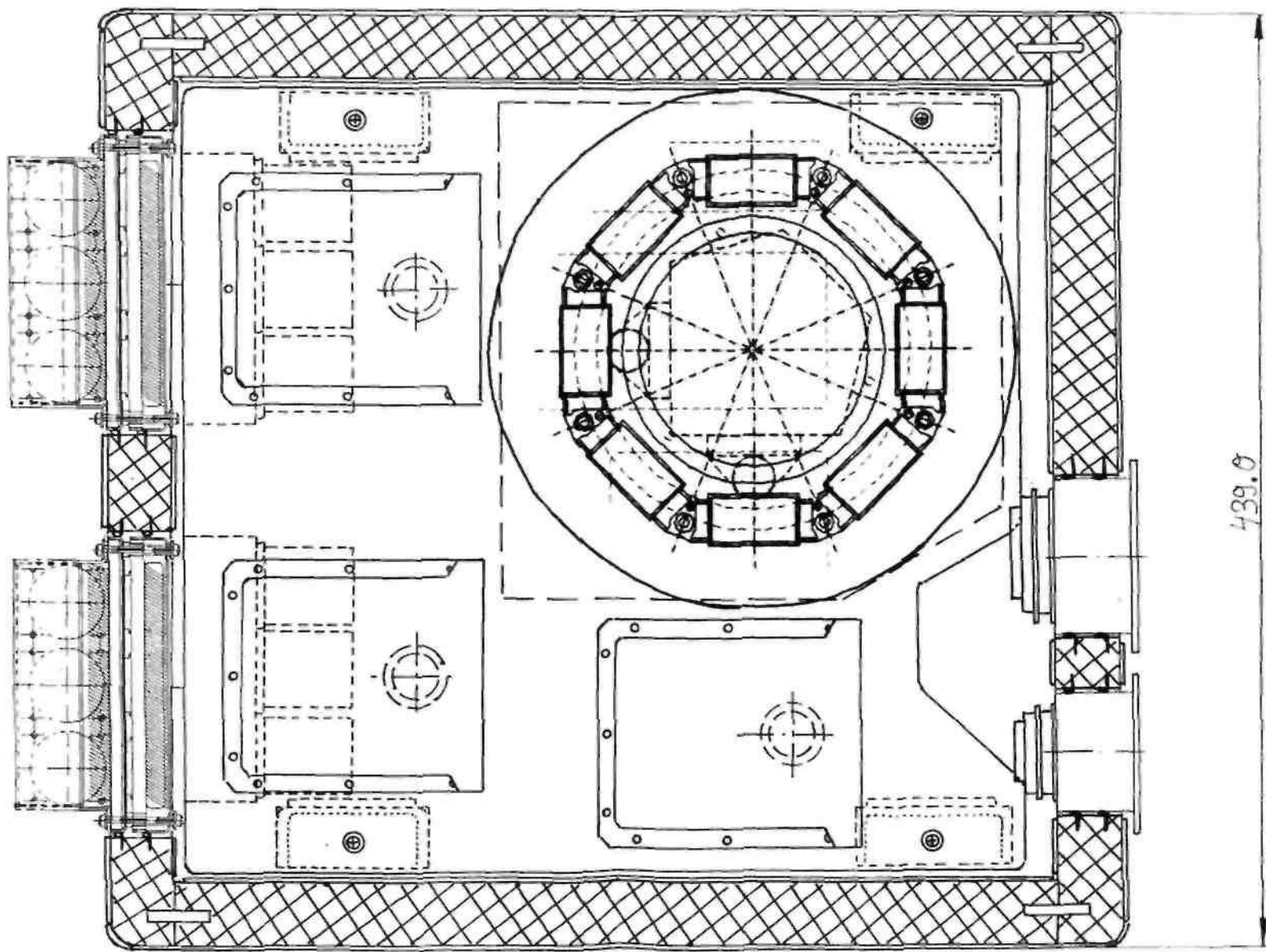

439.0

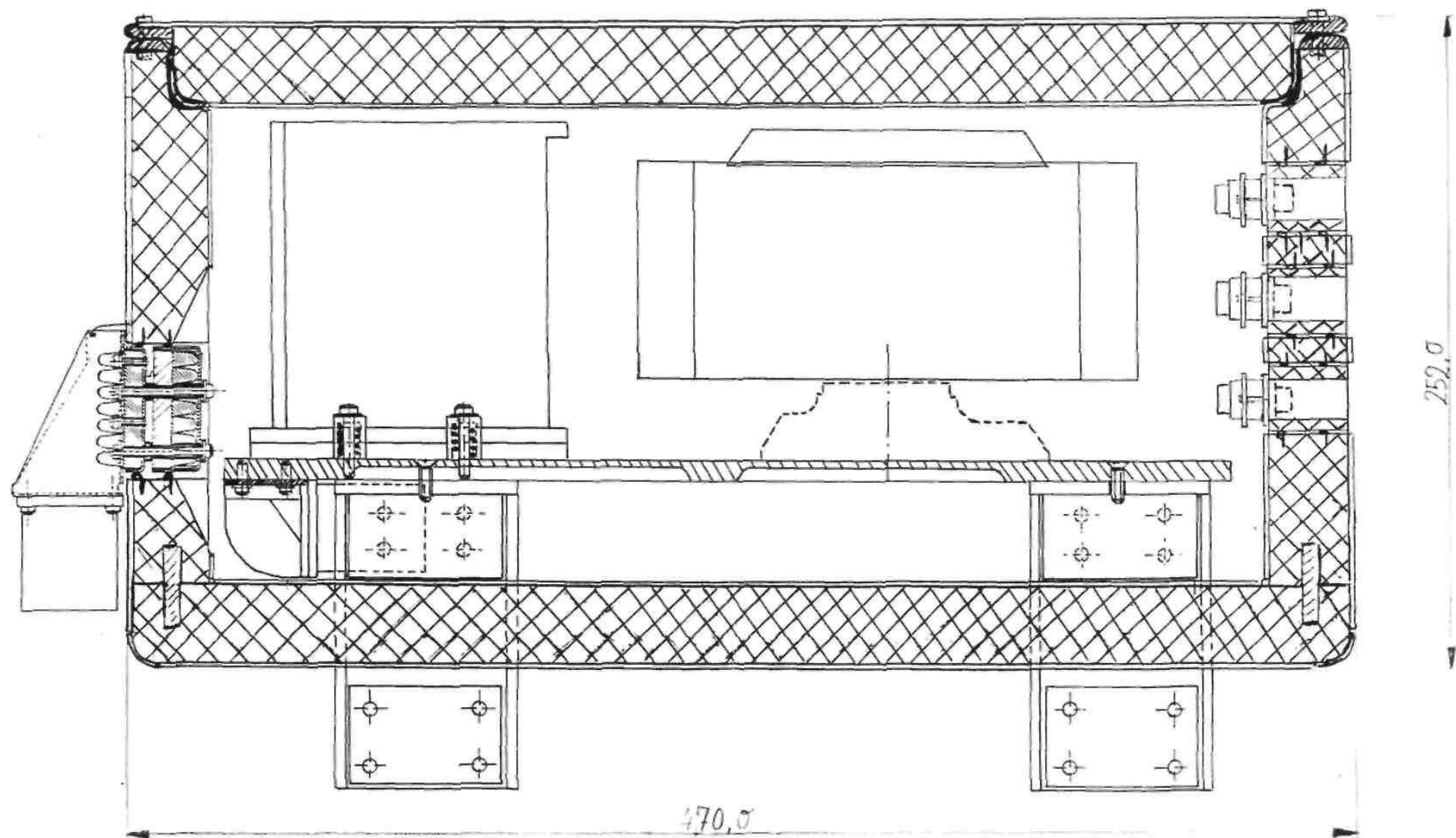

BIOBOX : Thermal Concept

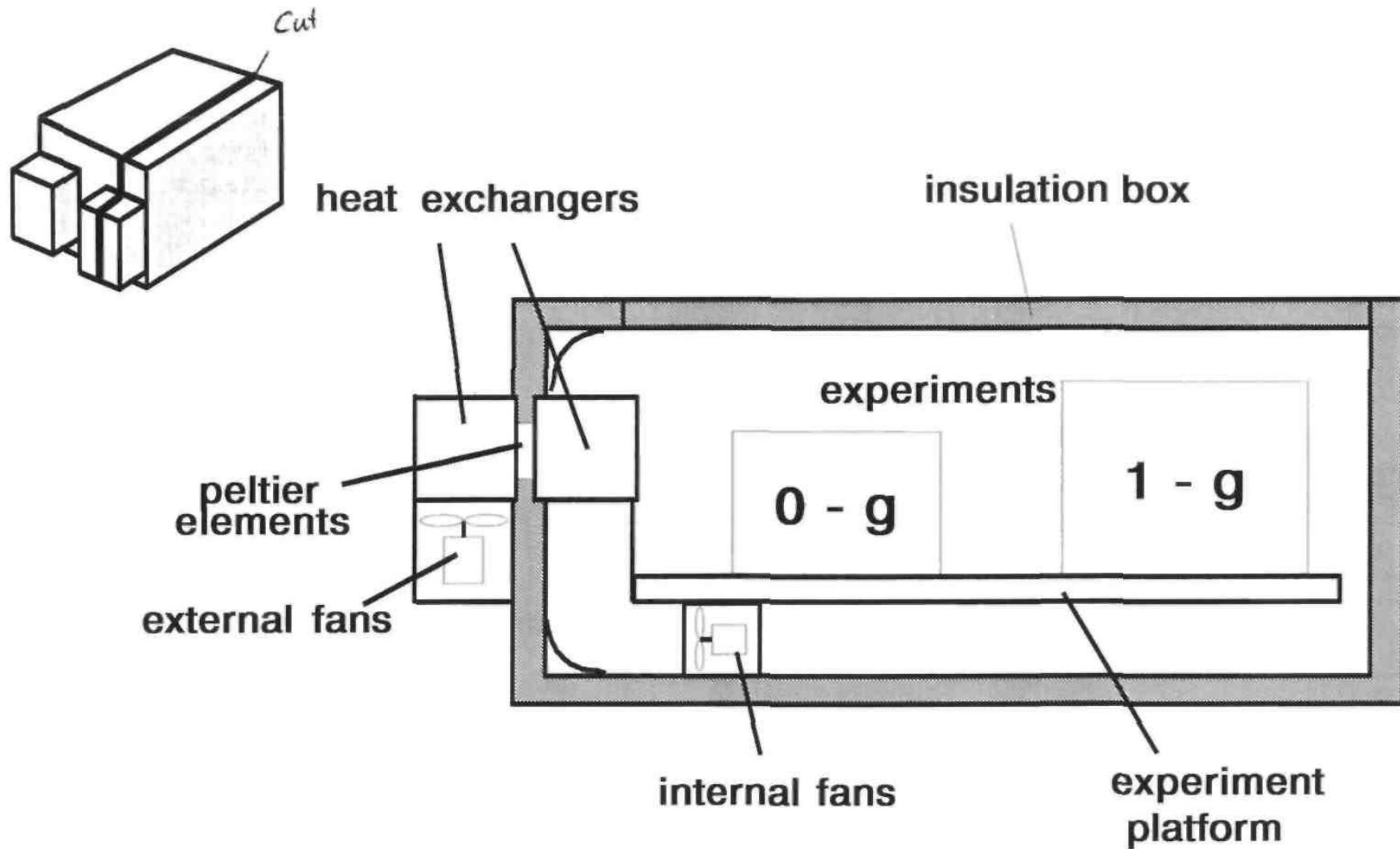

BIOBOX 1-g Centrifuge Subsystem

ELECTRONICAL REQUIREMENTSPerformances:

- Speed
 - * 107 rmp set speed
 - * (1-g in geometrical centre of experiment **container ECI**)
 - * speed accuracy of g-level $< \pm 2\%$

- maximum acceleration time 40±4s
- linear acceleration and deceleration
- max. cont. motor power dissipation 2 W
- max. peak motor power dissipation 4 W max. 40 s

Control electronics:

The Centrifuge Control Electronic controls all **phases of the 1-g Centrifuge and delivers housekeeping data to Facility Control System**. The phases are :

- power on
- start centrifuge
- run centrifuge at set-speed
- stop centrifuge
- power off

BIOBX

CENTRIFUGE MECHANICAL MODIFICATIONS

CARRAR

2. LARGER BEARINGS
ARE IMPLEMENTED

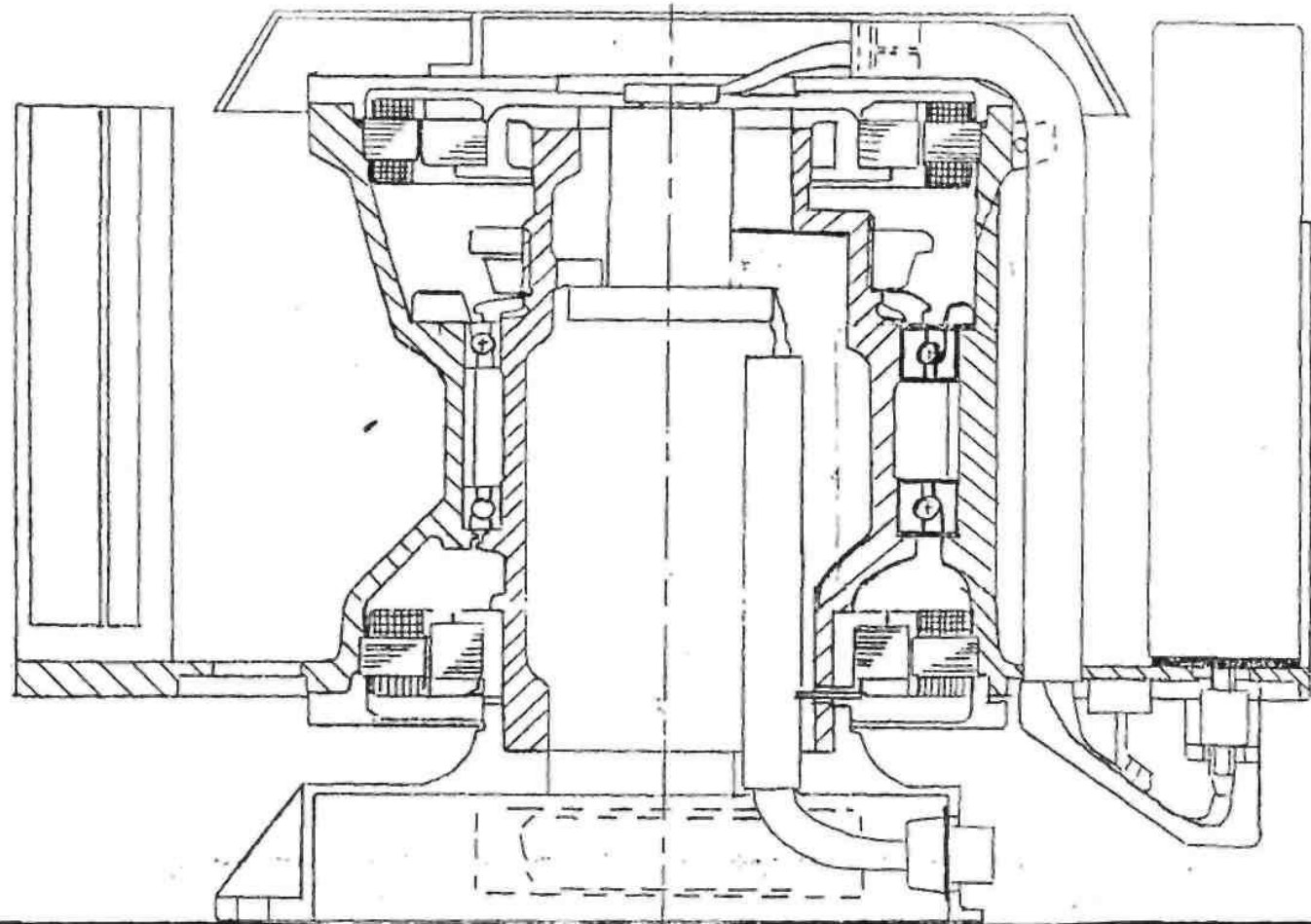

BIOBX

CENTRIFUGE MECHANICAL MODIFICATIONS

CARRAR

GENERAL VIEW
OF THE LOCKING
DEVICE

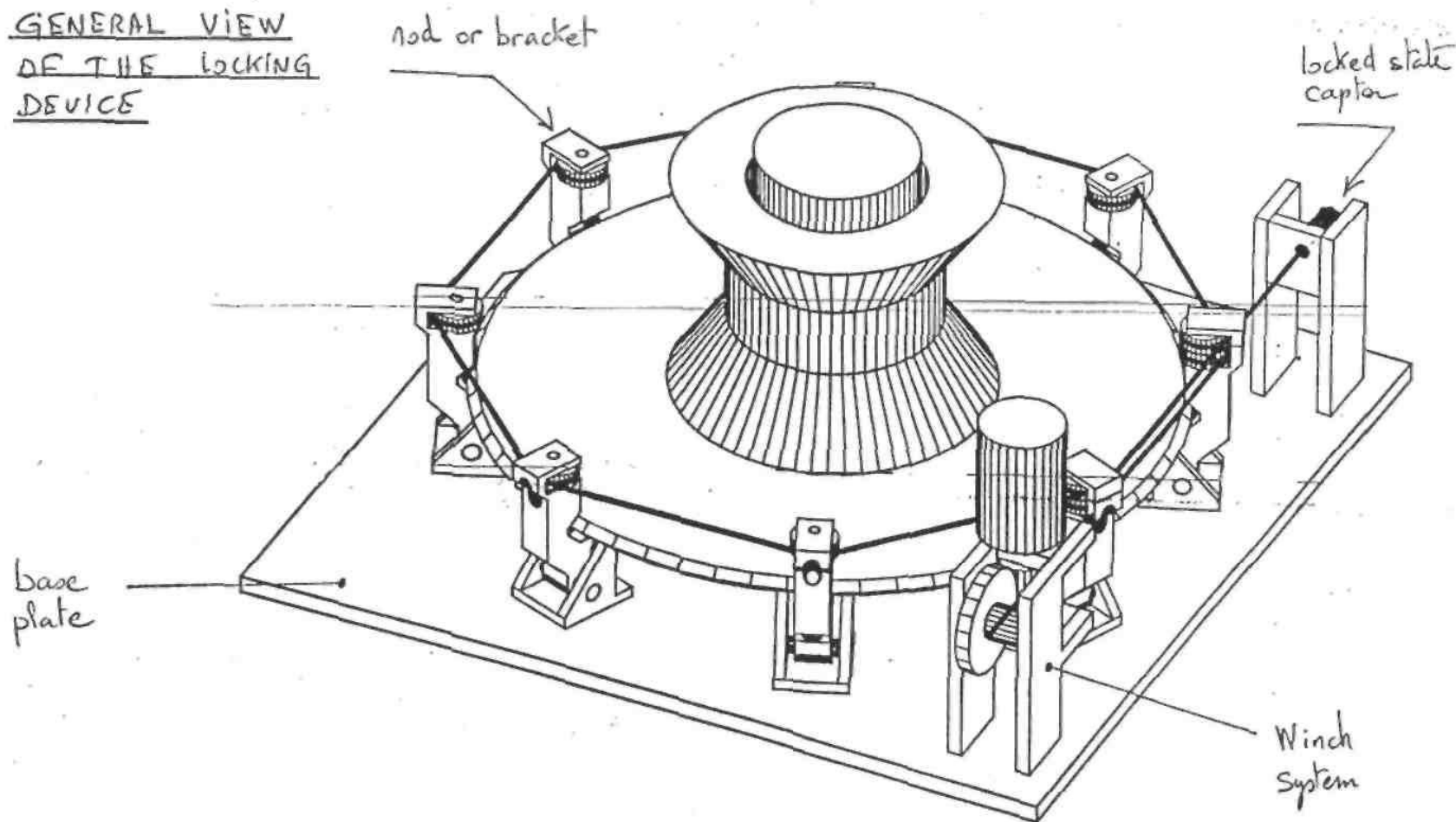

BIOBX

CENTRIFUGE MECHANICAL MODIFICATIONS

CARRAR

THE BRACKET SYSTEM: PROPOSED DESIGN

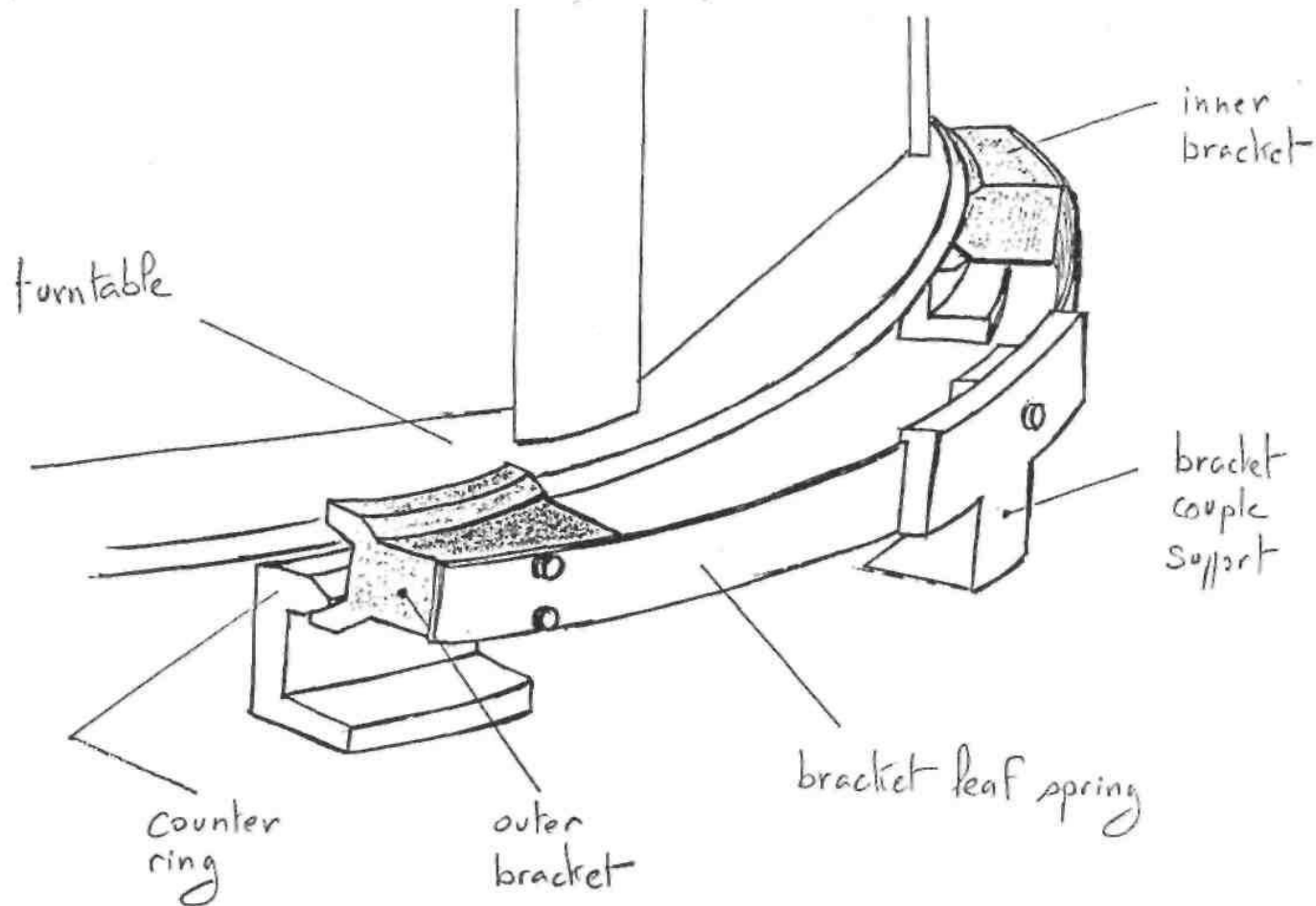

BIOBOX

CENTRIFUGE MECHANICAL MODIFICATIONS

CARRAR

MECHANICAL INTERFACE SOLUTION 2 : FIXATION OF THE CONNECTORS

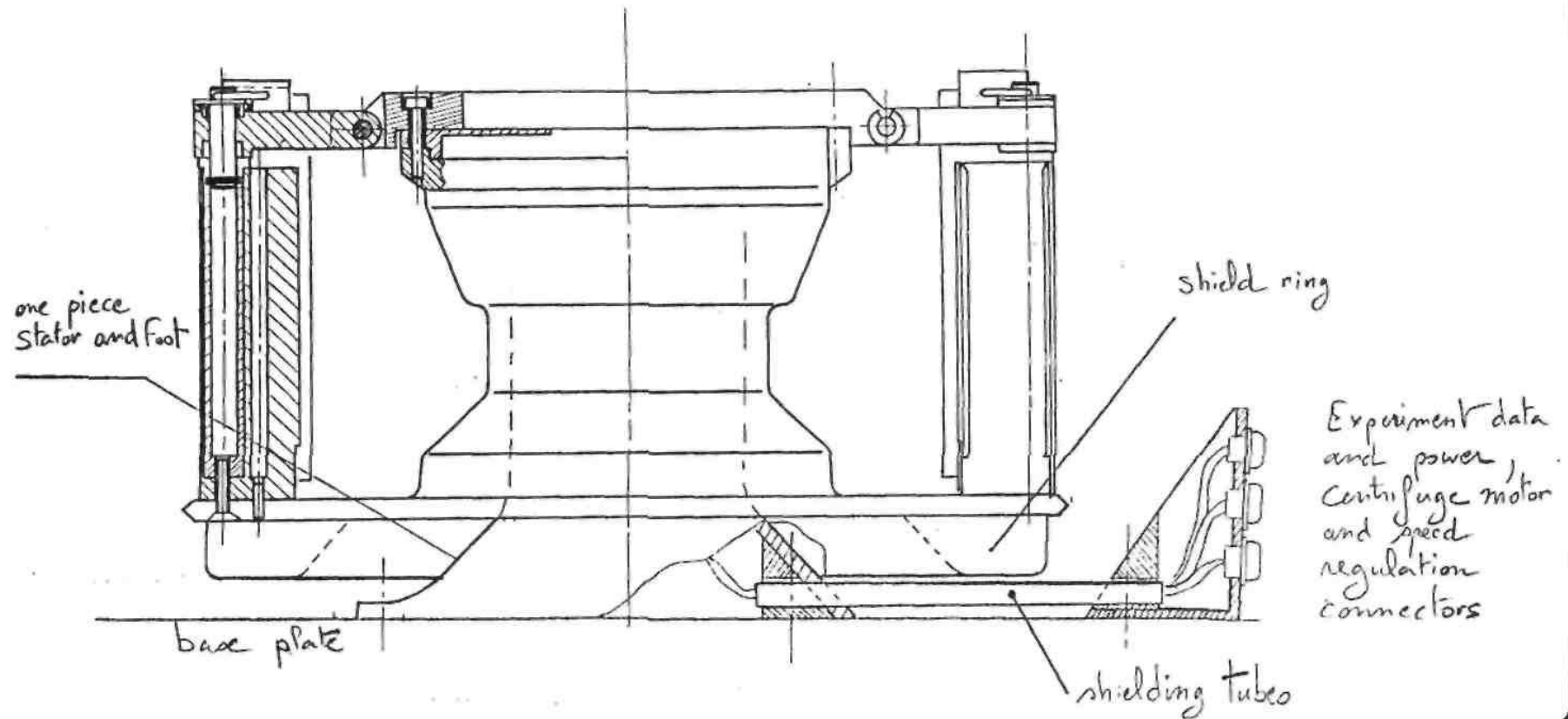

BIOBX

CENTRIFUGE MECHANICAL MODIFICATIONS

CARRAR

3. LOCKING DEVICE TO SUPPORT 100% OF THE AXIAL LOADS

TOP VIEW

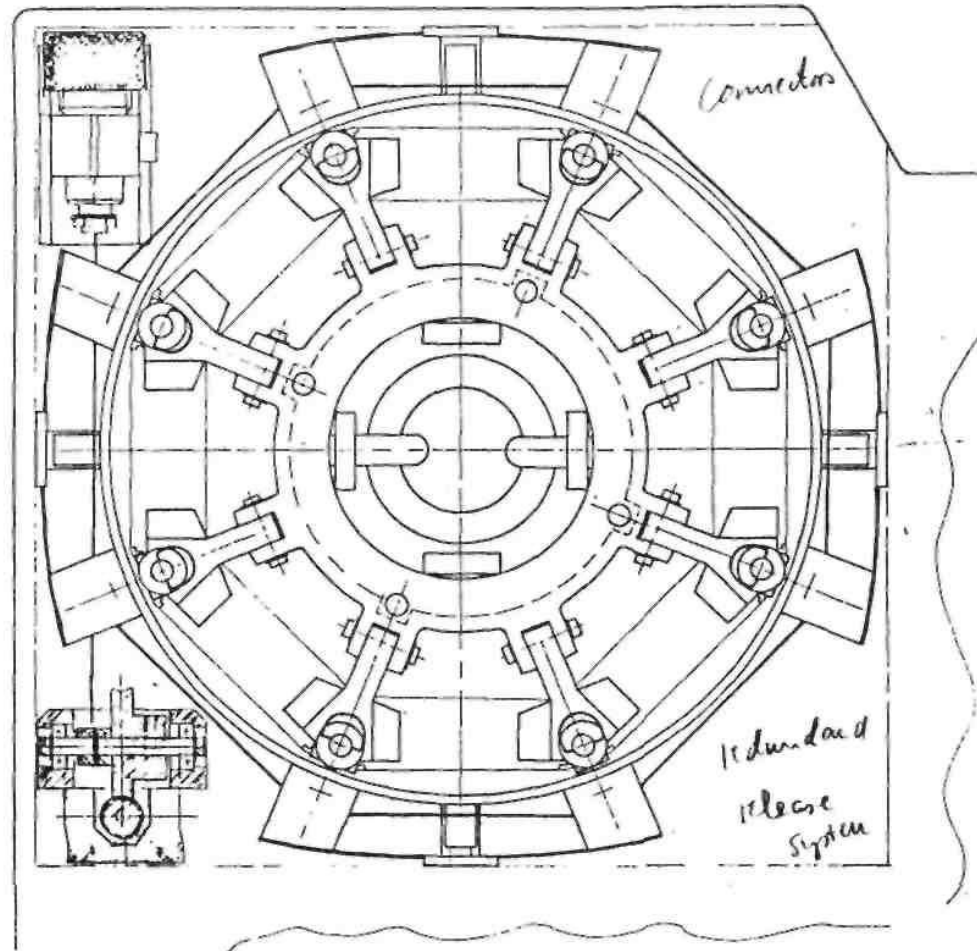

Top View - Location numbering

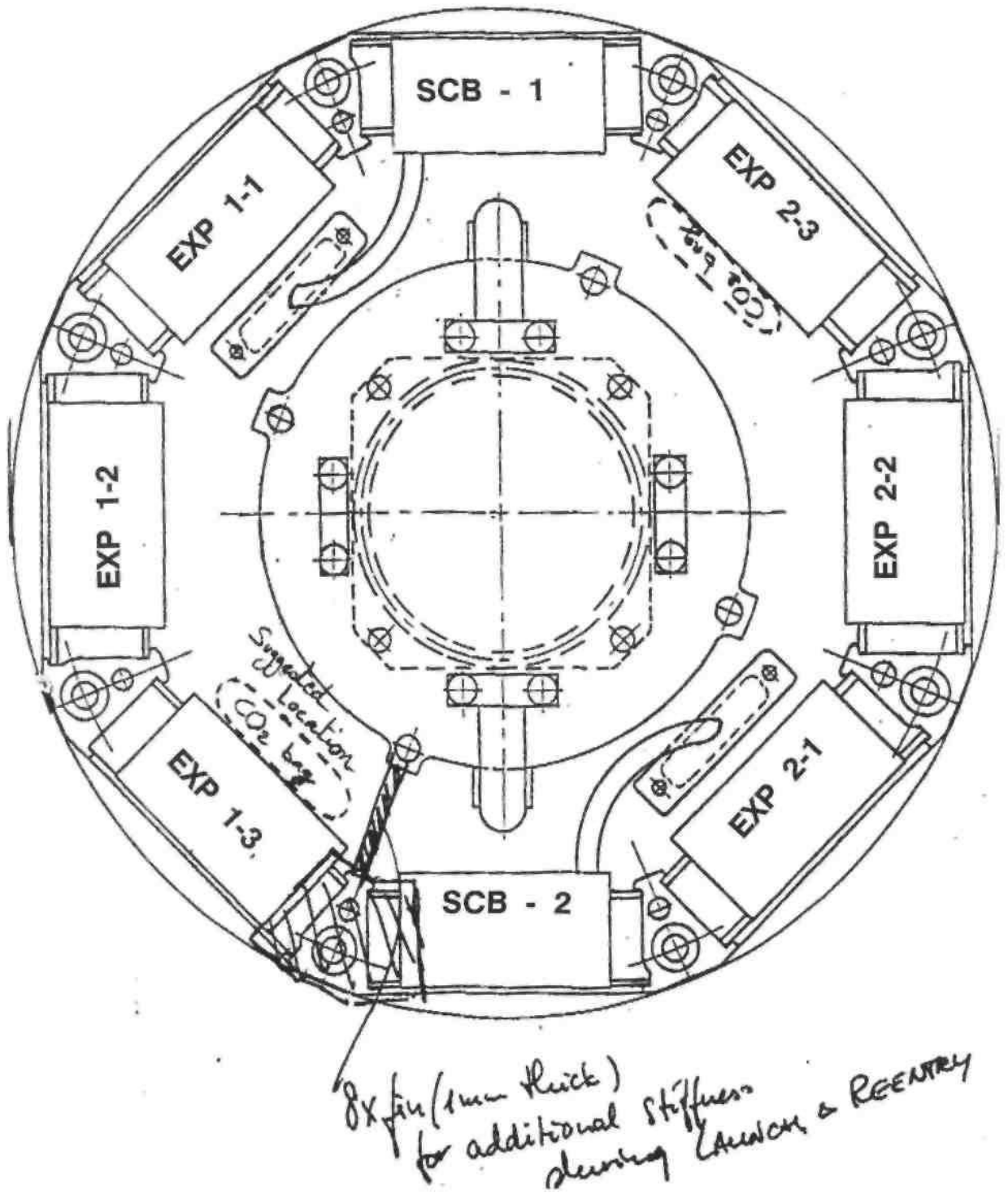

BIOBOX - CO₂ capabilities

for Experiments on the Centrifuge

Option A: Rigid 'Backpack' case on EC IE Containers

Maximum outer dimensions: 30mm • 10mm • appr. 70mm

=> Maximum Volume: 21 cm³

Option b: Flexible Plastic bag

=> Volume: up to appr. 45 cm³

Side view of the centrifuge

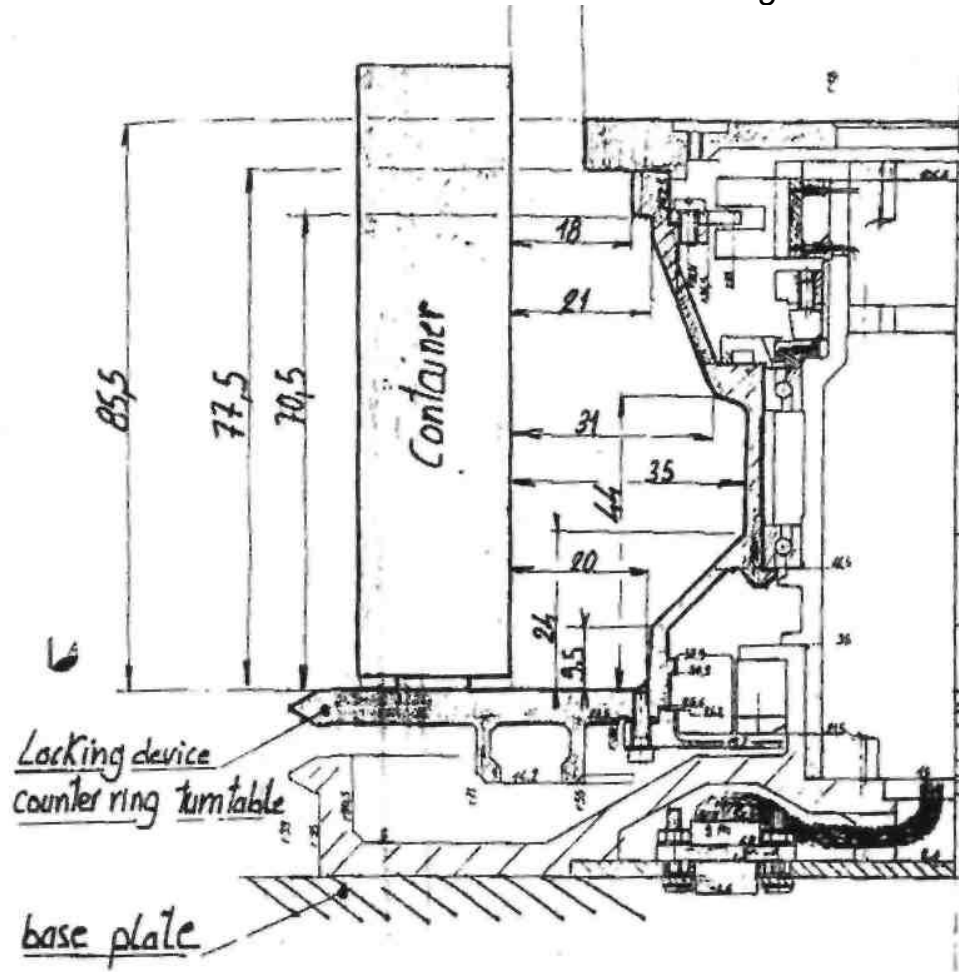

Top view of centrifuge

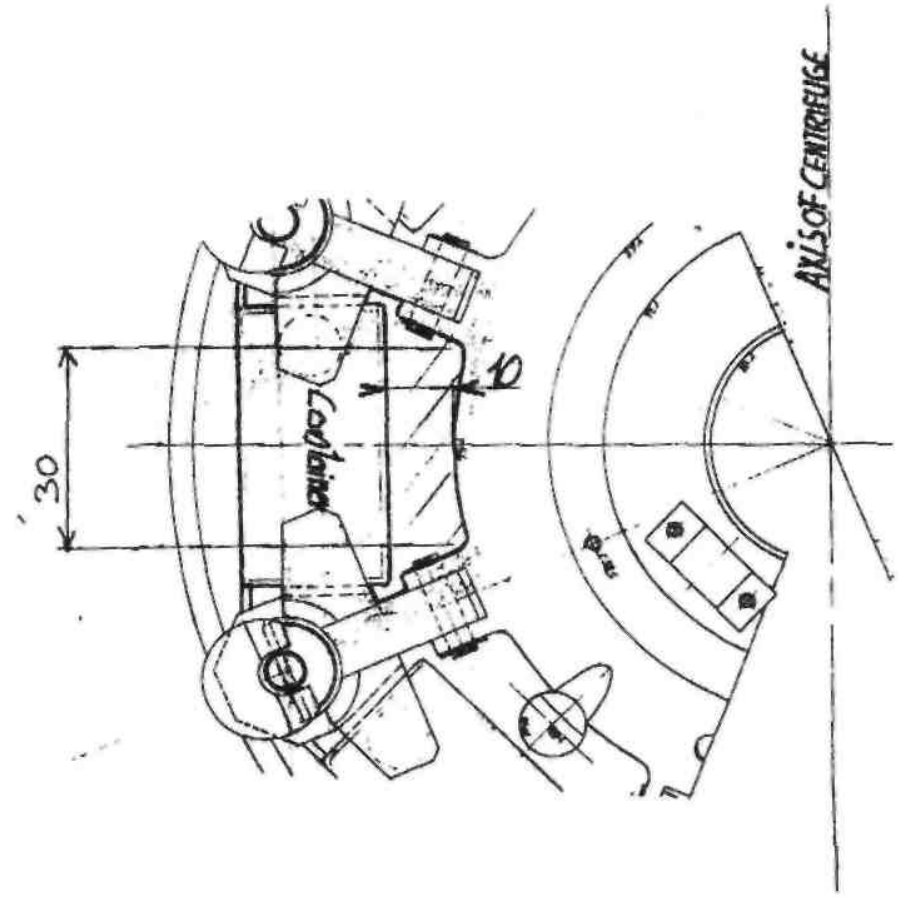

Biobox Facility Control

Facility Control Electronics Features

- control of BIOBOX temperature program
- start / stop experiment program
- data acquisition and storage of housekeeping data
- data acquisition and storage of experiment data
- reception of telecommands
- transmission of telemetry data
- control of internal devices

BIOBOX - Channel Distribution

Analog Channels (Input to Controller Board)

Numbers of Channels available:	48
Number of Channels for BIOBOX Control:	19
Number of Channels for Experiments (now used):	11

Digital Channels (Input to Controller Board)

Numbers of Channels available:	32
Number of Channels for BIOBOX Control:	12
Number of Channels for Experiments (now used):	5

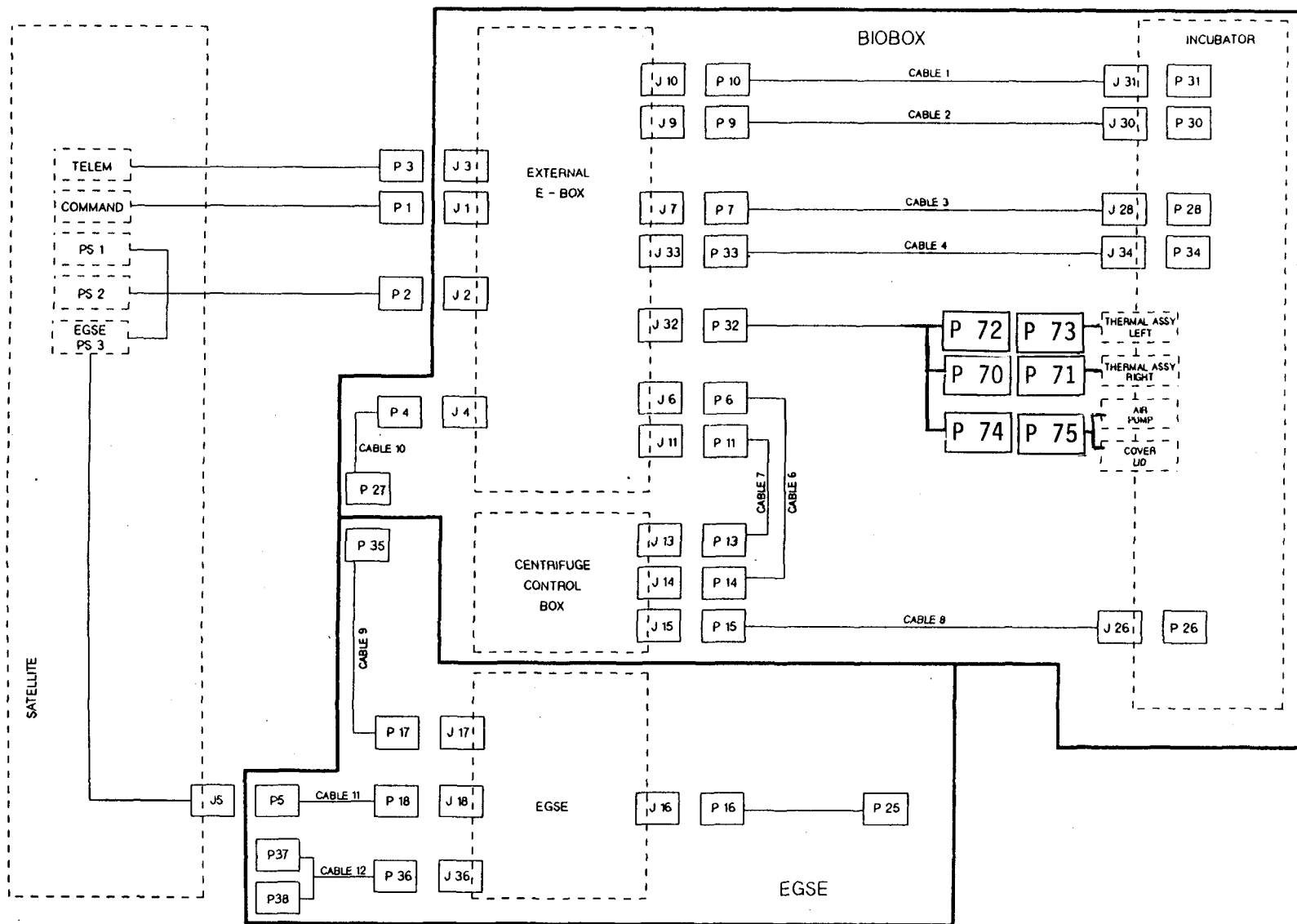

= HARNESS DIAGRAM =

Incubator Harness

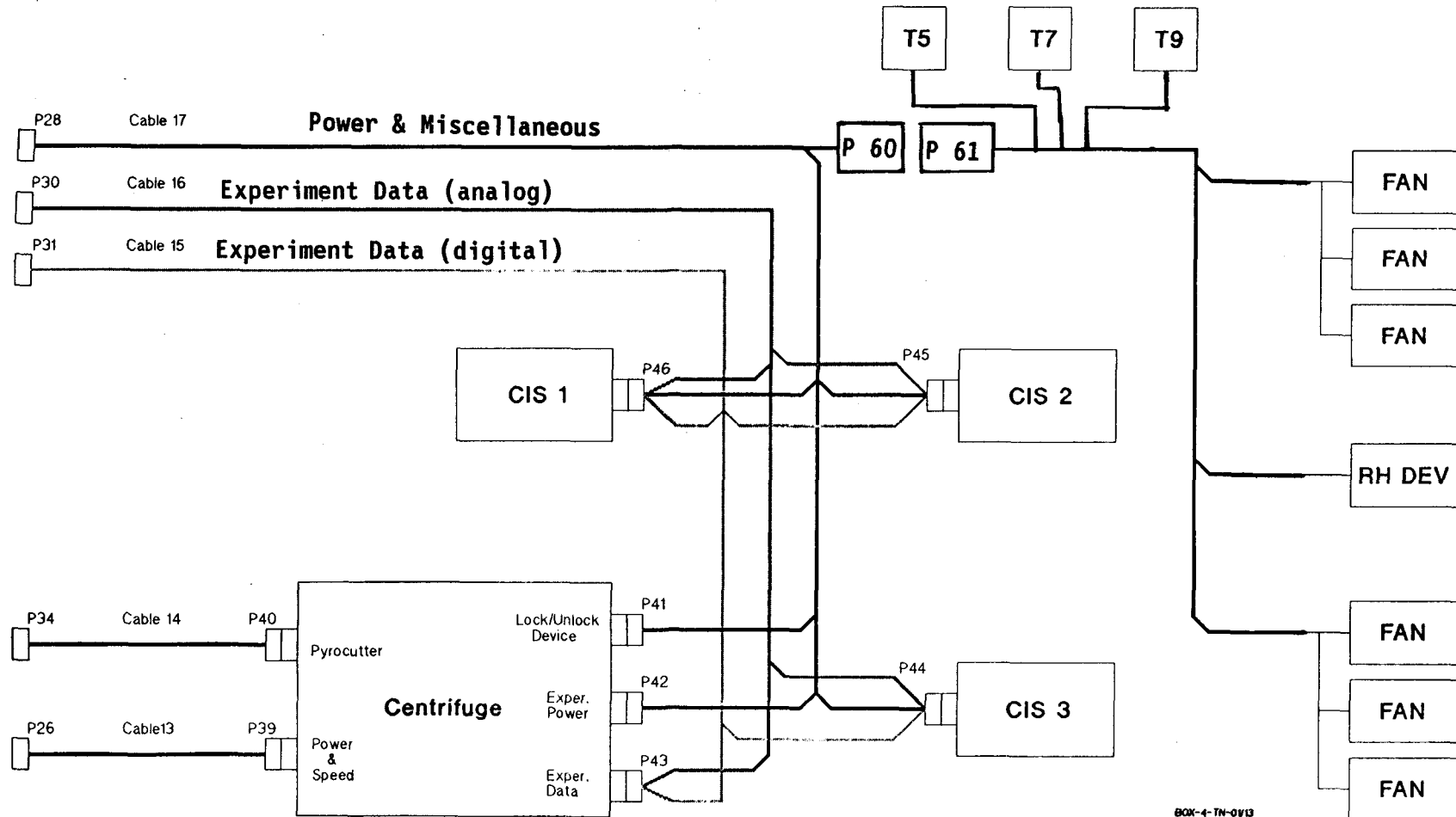

1-K17"51P"

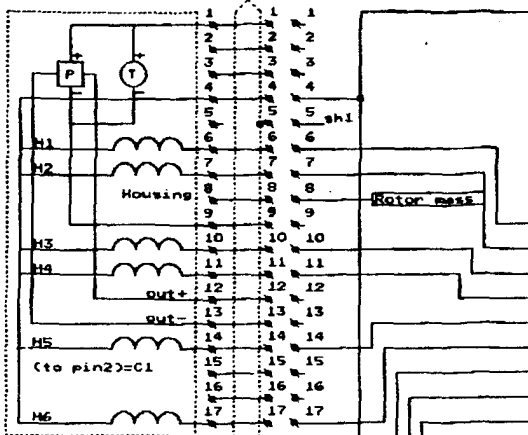

2-K17

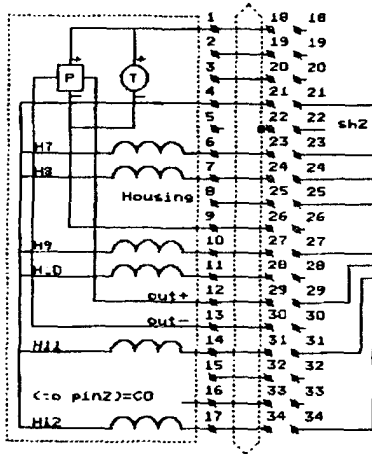

3-K17

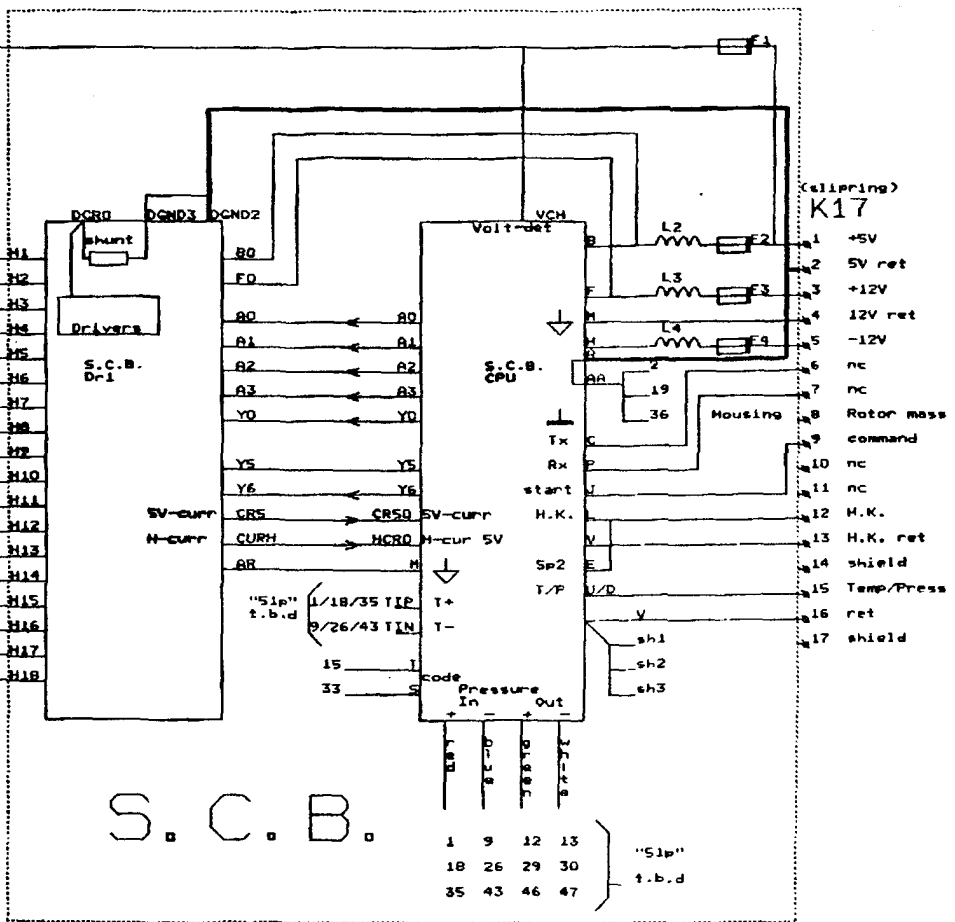
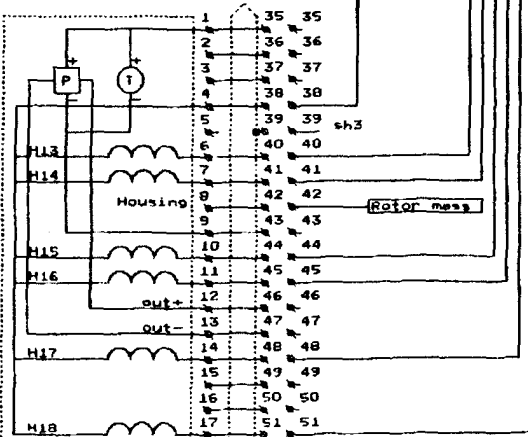

- (clipping)
K17
- 1 +5V
 - 2 5V ret
 - 3 +12V
 - 4 12V ret
 - 5 -12V
 - 6 nc
 - 7 nc
 - 8 Rotor mass
 - 9 command
 - 10 nc
 - 11 nc
 - 12 H.K.
 - 13 H.K. ret
 - 14 shield
 - 15 Temp/Press
 - 16 ret
 - 17 shield

S . C . B .

"51p" t.b.d	1/18/35 TIP	T+	1	9	12	13
	2/26/43 TIN	T-	18	26	29	30
			35	43	46	47



CISB1OP.wp
24-apr-1991

CIS-Box Connector: Souxiau 851
Pin allocation 8S1-02H-14-19-P-N-50

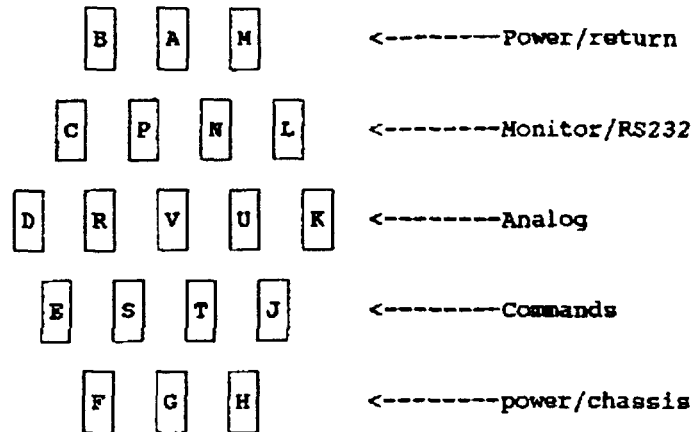

Solder side "vacuum" part

Pin Allocation CIS-box BIOB-10

CISbox side	"Cable"-side
Souriaux 851-02H-14-19P-W-50	Sonrioux 851-...-14-19S-W-S0
A = +5 Vdc Ret	+5 Vdc Ret _____
B = +5 Vdc	+5 Vdc _____
L = Monitor-1 H.K.	H.K. _____
N = Testpin syn1	nc _____
P = Testpin RX (RS232)	nc _____
C = Testpin TX < RS232)	nc _____
K = testpin H_curr	nc _____
U = analog-2 Temp1	Temp-1 _____
R = analog-3 Temp2	Temp-2 _____
D = analog-4 Press	Press _____
V = analog signal return	analog sign ret _____
J = spare	nc _____
T = Command start	Start _____
S = spare	nc _____
E = spare	nc _____
H = - Va = -12 Vdc	- 12 Vdc _____
F = + vd = +12 Vdc	+ 12 Vdc _____
H = +/-12 Vdc ret	+/- 12 Vdc ret _____

G = connected with wire the housing (bounding)

Rem: pin V is internal connected to pin M

BIOBOX Mission Operation

Nominal Operation Flow

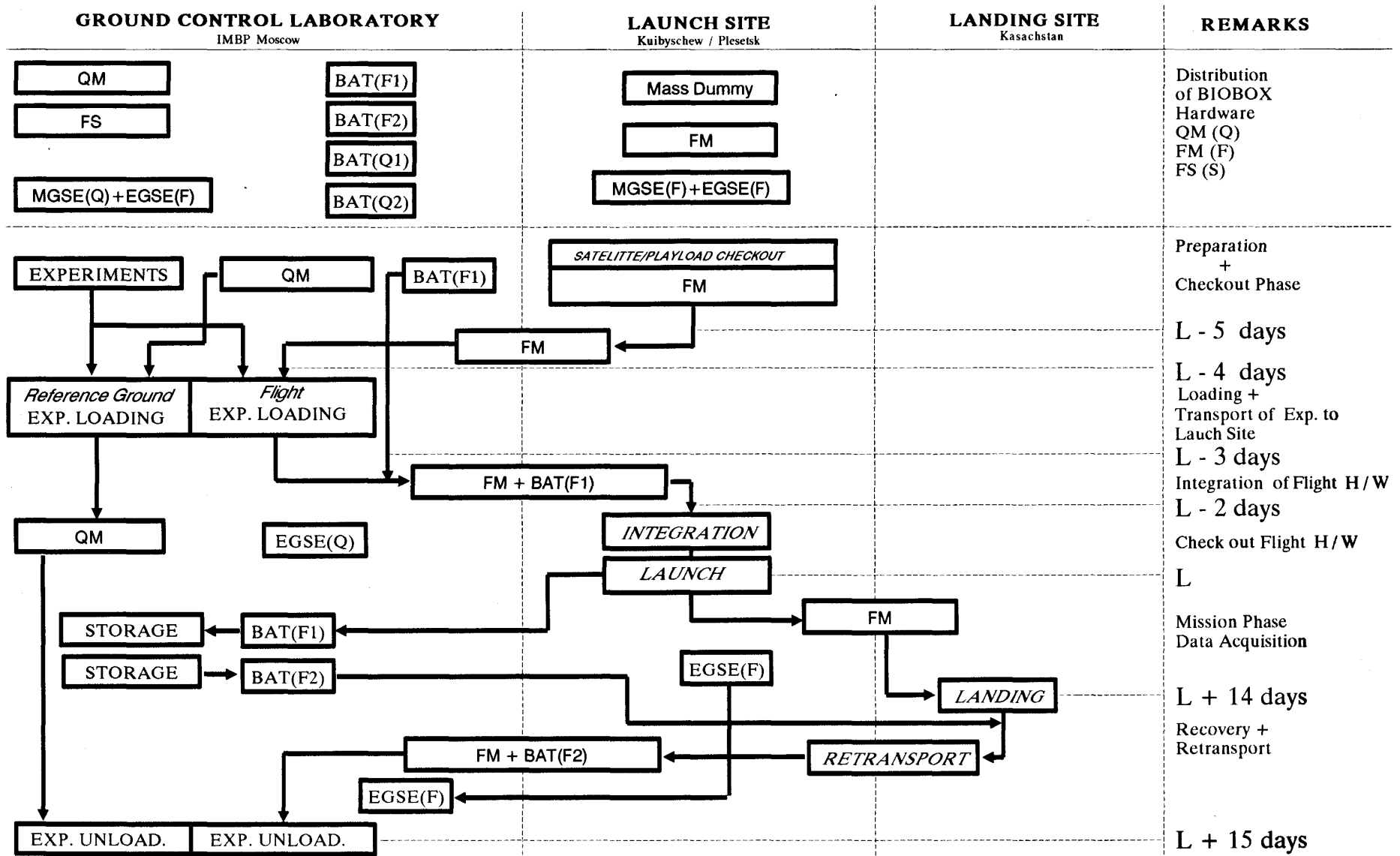

Emergency Operation Flow

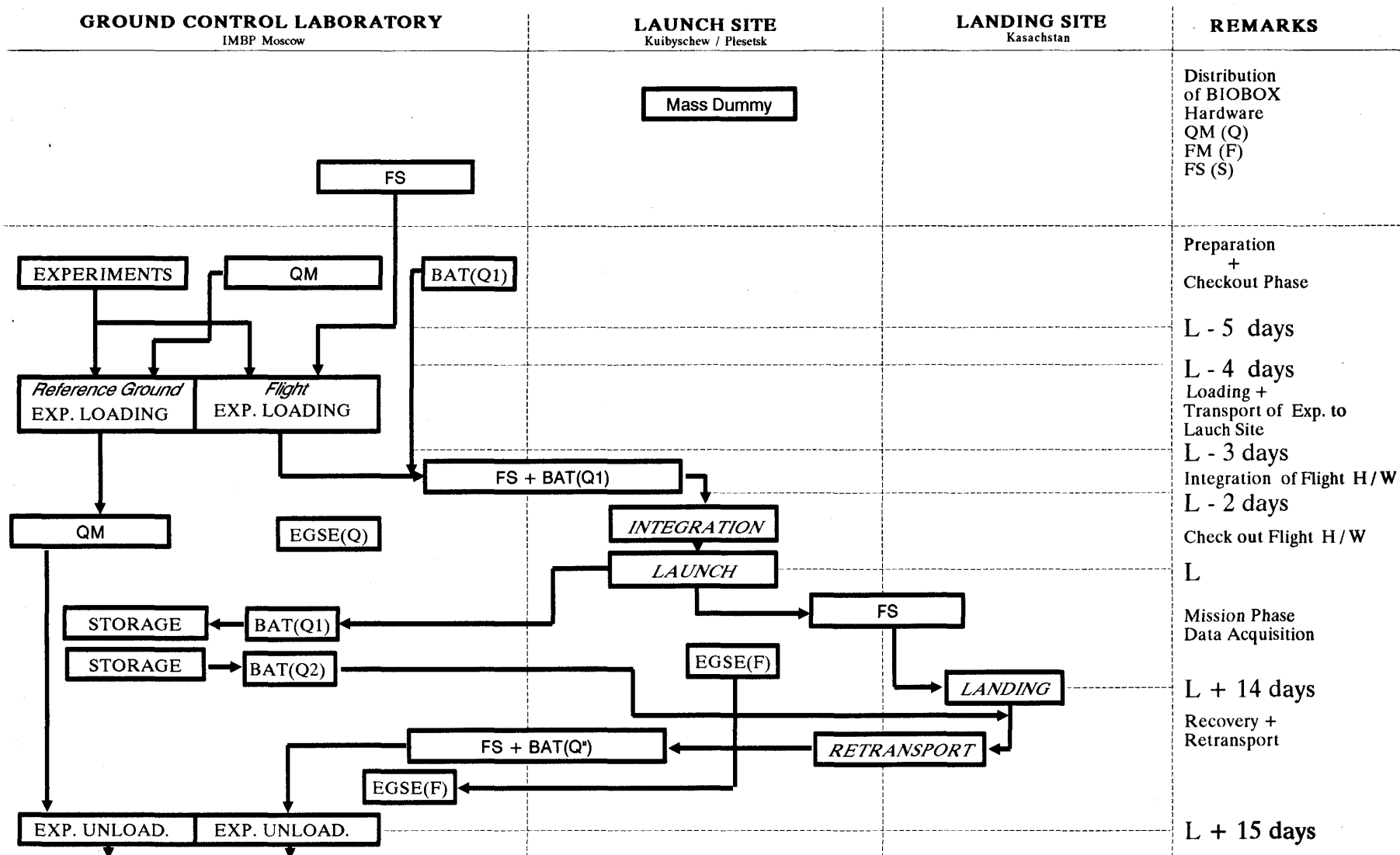

BIOBOX - Sample Interfaces

BIOBOX features:

- power for experiments
- temperature controlled environment
- one-g centrifuge
- start commands
- recording of user specified experiment signals

Experiment Loading Capability:

- 3 CIS Containers (on Experiment Plate)
- 6 EC IE Containers (on Centrifuge)

Experiment Control Capabilities:

- Start Experiments
- Activate Plungers

Experiment Reporting Capabilities:

- Housekeeping Data
 - Experiment in progress
 - Experiment finished
 - Temperature/Pressure in EC IE Containers
 - Temperature/Pressure in CIS Containers

Facility Operation Flow

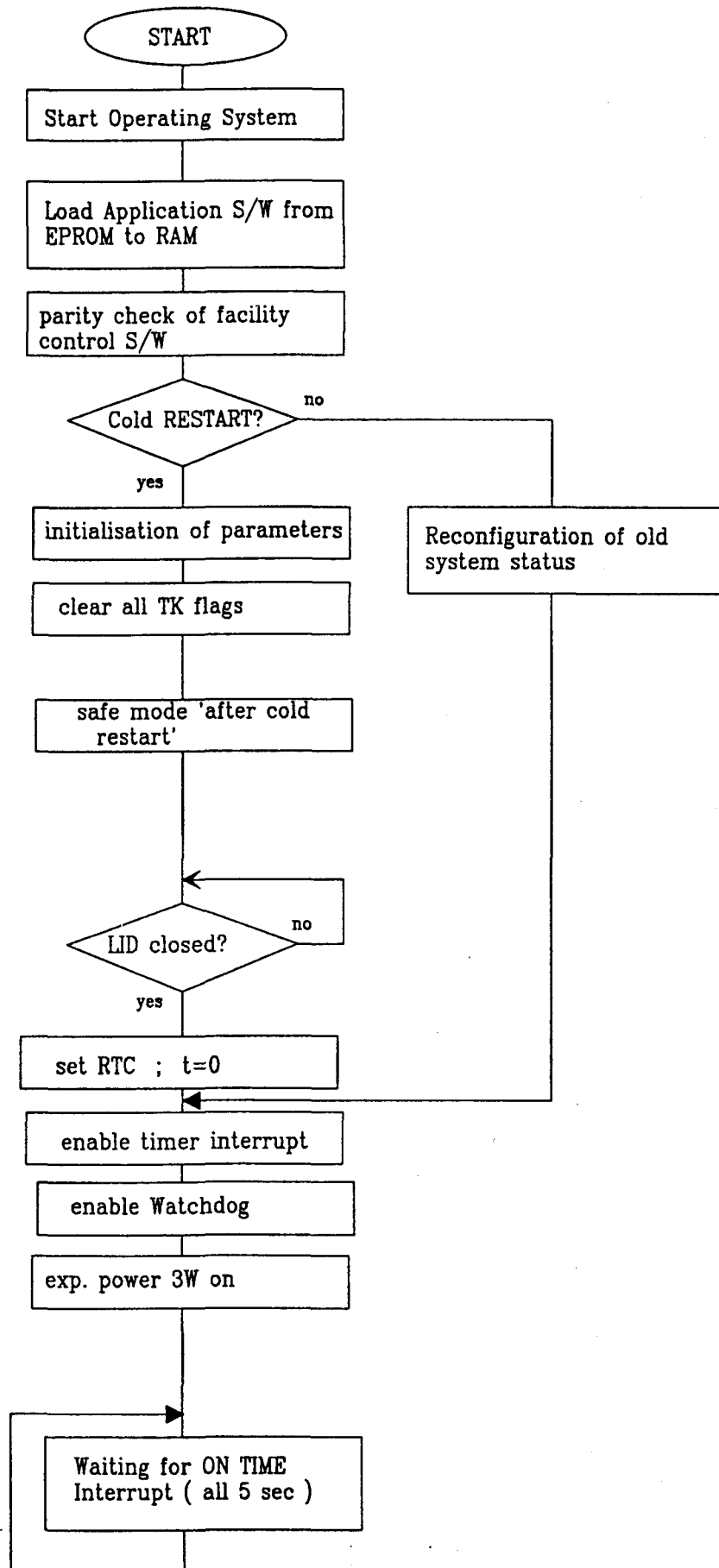

timer interrupt all 5 sec.

read data set A
- temperatures
- process control
- peltier current
- g-sensor
- TKs
- HK data

set TK S/W flags
clear TK H/W flags

Calculate new output for
peltier controller

Verify new peltier controller
output

Set new peltier controller
output

store actual system
configuration +status for
restart

calculate g-sensor
filter values
Filter 1
Filter2

every second
pass

Retrigger Watchdog

read data Set B
- experiment data
- HK data

prepare data
- set A
- set B
before storage

command processing

safety supervision

environmental control
(option)

all tbd
increments

data storage

RETI

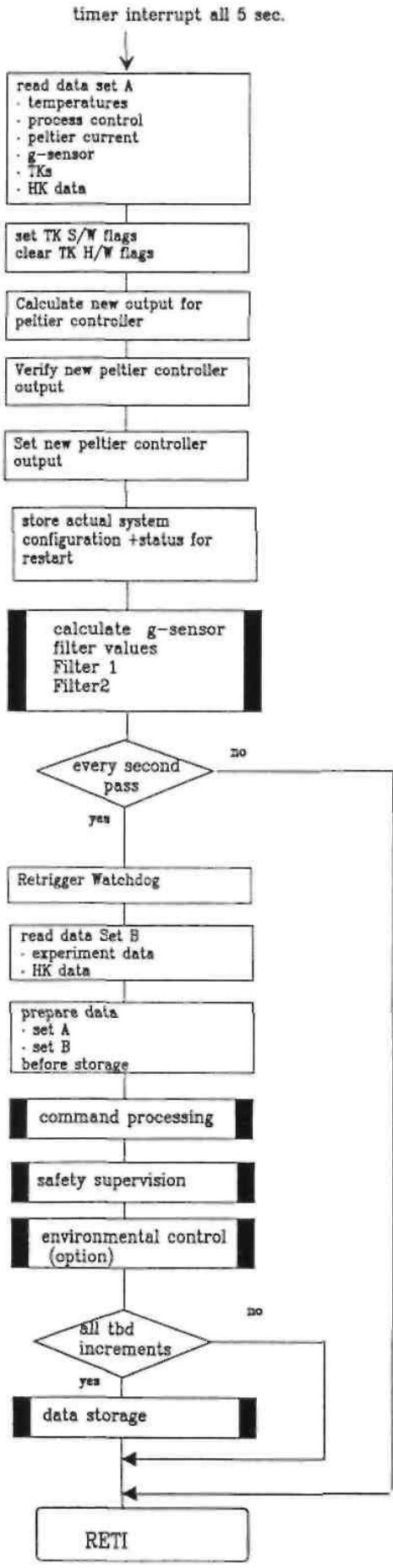

BIOBOX CONTROL EVENTS

EVENT	CONDITION	HARDWARE STATUS							REMARK
		TEMPERATURE-CONTROL		FANS	CENTRIFUGE	POWER	EXPERIMENT		
		STATUS	ACTION				SIGNALS	EXP-DATA	
S	last exp.-power ON	ON	keep T-Launch	ON	locked; stopped	ON	—	read & store	—
A1	TK1	ON	start heating to T-Exp.	ON	unlock; start	ON	—	read & store	set "IN-ORBIT FLAG"
A2	µg after launch	ON	start heating to T-Exp.	ON	unlock; start	ON	—	read & store	set "IN-ORBIT FLAG"
A3	t = S + t1	ON	start heating to T-Exp.	ON	unlock; start	ON	HK of all 5exp.: "RUN"	read & store	ca. auto-start of exp.; set "IOF"
B1	T = T-EXP.	ON	keep T-EXP.	ON	running	ON	command to all 5 exp.: "START"	read & store	—
B2	T=T-EXP.	ON	keep T-EXP.	ON	running	ON	command to all 5exp.: "START"	read & store	—
B3	T = T-EXP.	ON	keep T-EXP.	ON	running	ON	—	read & store	—
C1	all 5 exp. ready	OFF	passive cooling to RT	ON	stop; lock	ON	HK of all 5exp.: "READY"	read & store	—
C1'	t = B1 + t2	OFF	passive cooling to RT	ON	stop; lock	ON	—	read & store	exp. time-out
C2	all 5 exp. ready	OFF	passive cooling to RT	ON	stop; lock	ON	HK of all 5 exp.: "READY"	read & store	—
C2'	t = B2 + t2	OFF	passive cooling to RT	ON	stop; lock	ON	—	read & store	exp. time-out
C3	all 5 exp. ready	OFF	passive cooling to RT	ON	stop; lock	ON	HK of all 5 exp.: "READY"	read & store	—
C3'	T = B3 + t2	OFF	passive cooling to RT	ON	stop; lock	ON	—	read & store	exp. time-out
T	TK2	ON	active cooling to T-Storage	ON	stop; lock	ON	—	read & store	stop of exp; reentry preparation
D	t = S + t3	ON	active cooling to T-Storage	ON	stop; lock	ON	—	read & store	reentry preparation
U	switch to AUX. POWER	ON	active cooling to T-Storage	ON	stop; lock	ON	—	read & store	reentry preparation
V	end of µg in-orbit	ON	active cooling to T-Storage	ON	stop; lock	ON	—	read & store	reentry preparation

LEGEND: T : Temperature; TK1: tele-command: "START EXPERIMENT SEQUENCE"
t : time TK2: tele-command: "STOP EXPERIMENT SEQUENCE"; reentry preparation
IOF: IN_ORBnr FLAG

t1: auto-start of experiments by internal CIS- and SCB-timer after last event of experiment power ON at S
t2: experiment time-out; t2 = t-heat to T-Exp. + nominal t-Exp. + t-Contingency
t3: time-out for reentry preparation; time-condition to replace missing TK2

BIOBOX - Operations Flow

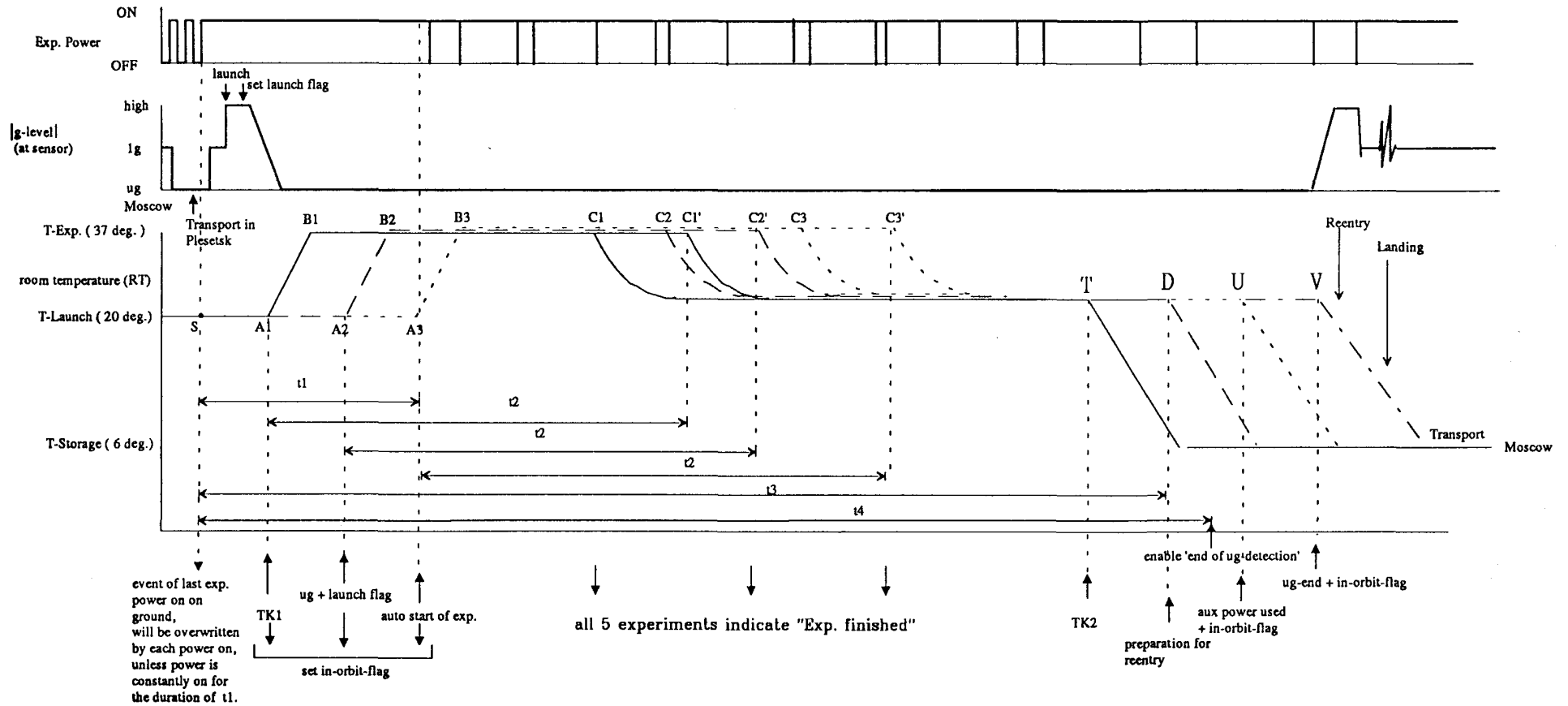

BIOBOX - Experiment Timeline (CIS & EC 1E Containers)

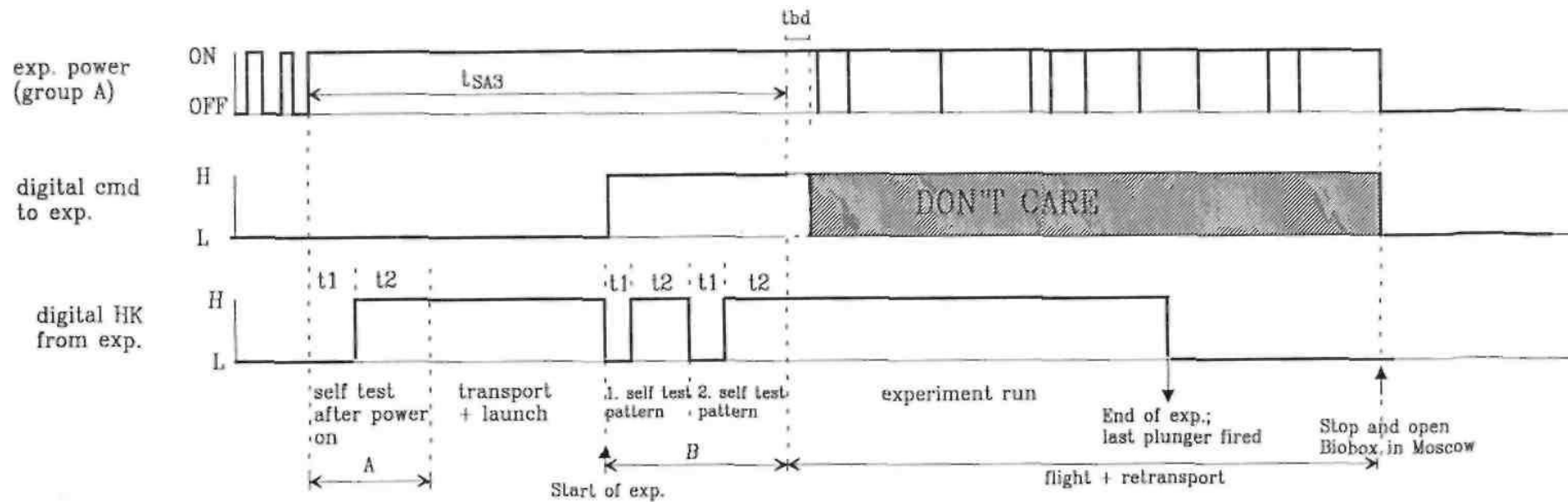

Explanations and remarks:

- experiment power on (group A) is common for all experiments
- in case of power loss after the experiment start command there will be no further experiment Start command from the facility controller
 - the experiment has stored its internal experiment time line protocol and will continue the experiment protocol automatically
- the 'start of experiment' command can be replaced by an internal timer (start = last experiment power on + tbd hours (tSA3))
- a wrong HK self test pattern indicates a H/W error
 - in phase A: report status of all 5 HK signals to EGSE (via test connector) + record on memory card + HK signals available in TM package
 - in phase B: retry command 2 times + store status in memory card + HK signals available in TM package
- at the end of experiments: HK goes low; store info on memory card; if all 5 HKs are low then stop and lock centrifuge; disable peltiers -> cooling to room temperature (RT)

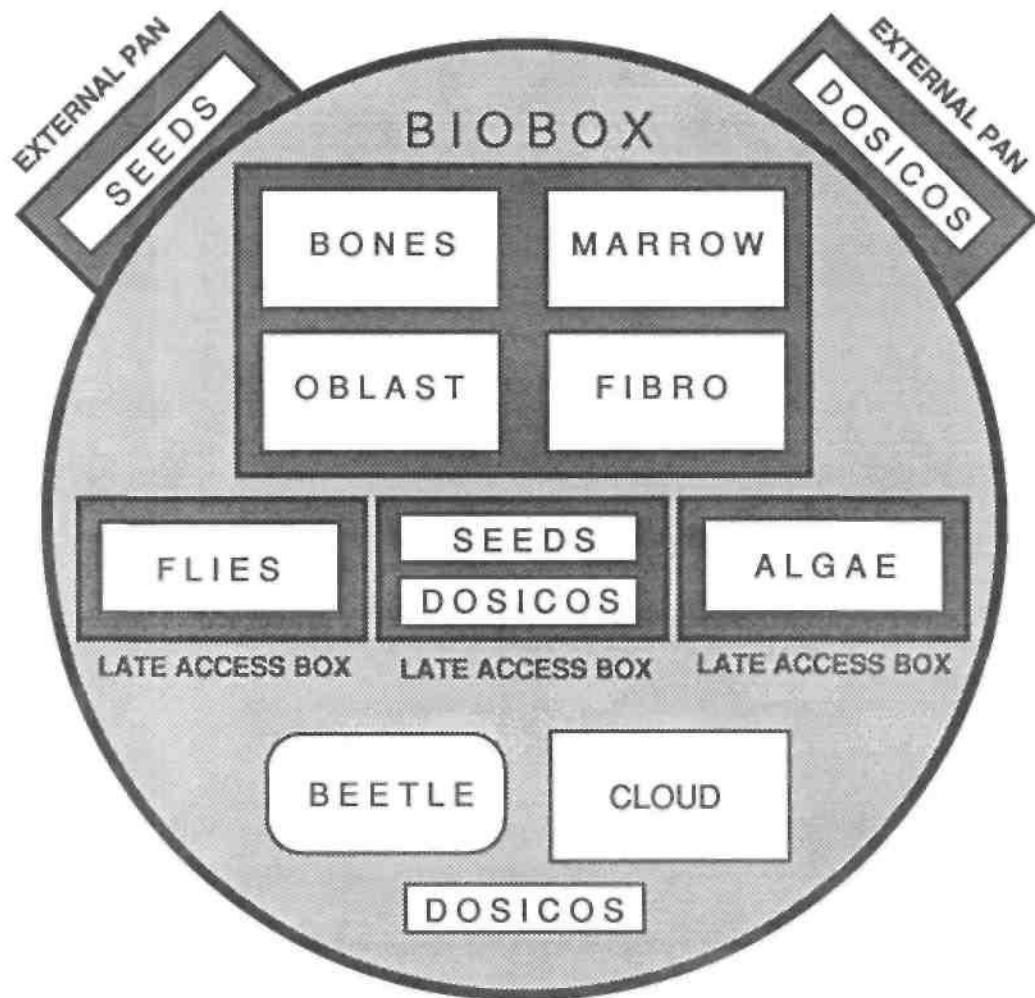

ESA / IBMP JOINT EXPERIMENTS

BION-10

ESA-EUROPEAN
SPACE AGENCY



IBMP-INSTITUTE
FOR BIOMEDICAL PROBLEMS,
MOSCOW

ESA / IBMP JOINT EXPERIMENTS ON BION 10

Expt Name Participating countries

1. BONES the Netherlands / USSR
2. MARROW Belgium / USSR
3. OBLAST France
4. FIBRO*# USSR/ F.R.Germany
5. FLIES Spain / USSR
6. CLOUD USSR / Spain
7. ALGAE the Netherlands / USSR
8. SEEDS F.R. Germany / France / USSR
9. DOSICOS F.R.Germany/USSR
10. BEETLE* USSR / Netherlands

* Joint experiment, but W-European PI not ESA-associated

Experiment hardware (plunger boxes) supplied by ESA

INVESTIGATORS

Principal investigators (Pis) printed in **bold**.

	ESA	USSR
1. BONES	J.P. Veldhuijzen E. Burger	A.S. Kaplansky N.V. Rodionova
2. MARROW	G. Schoeters J. Bierkens J. Maes	N.V. Rodionova
3. OBLAST	C. Alexandre C. Genty S. Palle	N.V. Rodionova
4. FIBRO	D. Hulser	M.G. Tairbekov LB. Margolis B.A. Baikakov
5. FLIES	J. Miquel E. de Juan R. Marco	I.A. Ushakov A.M. Alpatov
6. CLOUD	R. Marco J. Gonzalez-Jurado M. Maroto J. Miquel	I.A. Ushakov A.M. Alpatov
7. ALGAE	H. van den Ende E. van Spronsen	O.V. Gavrilova
8. SEEDS	A.R. Kranz E. Schopper B. Baican R. Seltz C. Heilmann J.-U. Schott K.E. Gartenbach	V.V. Shevchenko V.E. Dudkin Y.V. Potapov N.A. Nefedov
9. DOSICOS	G. Reitz R. Facius R. Beaujean M. Schaefer W. Heinrich	L.V. Nevsgodina E.N. Maximova A.I. Vikhrov V.E. Dudkin A.M. Marennny Y.V. Potapov A.B. Akopova
10. BEETLE	W. Rietveld	A.M. Alpatov Y.A. Evstratov V.B. Chemyshev V.A. Zotov

SCIENCE CO-OPERATION PER EXPERIMENT

	ESA-associated investigators	USSR-associated investigators
BONES		
Experiment design	X	
Hardware development	X	
Post-flight analysis	X	X
MARROW		
Experiment design	X	
Hardware development	X	
Post-flight analysis	X	X
OBLAST		
Experiment design	X	
Hardware development	X	
Post-flight analysis	X	X
FIBRO		
Experiment design	X	X
Hardware development	X	
Post-flight analysis	X	X
FLIES		
Experiment design	X	
Hardware development	X	
Post-flight analysis	X	X
CLOUD		
Experiment design		X
Hardware development		X
Post-flight analysis	X	X
ALGAE		
Experiment design	X	X
Hardware development	X	
Post-flight analysis	X	X
SEEDS		
Experiment design	X	X
Hardware development	X	X
Post-flight analysis	X	X
DOSICOS		
Experiment design	X	X
Hardware development	X	X
Post-flight analysis	X	X
BEETLE		
Experiment design		X
Hardware development		X
Post-flight analysis	X	X

SCIENCE OBJECTIVES

1. Microgravity studies

2. Radiation studies

Microgravity studies

Inevitably, all flight samples will be exposed to microgravity *and* cosmic radiation.

In the experiments BONES, MARROW and OBLAST part of the flight samples are mounted on a 1-g centrifuge.

Differences between centrifuged and static flight samples cannot be attributed to radiation.

Radiation studies

Inevitably, all flight samples will be exposed to radiation *and* microgravity. By choosing very small biological objects in combination with track detectors, it is possible to discriminate hit from non-hit objects. Differences between hit and non-hit objects cannot be attributed to microgravity.

(Note: it is still possible that a hit in micro-g is different from a hit at 1 -g)

1. Microgravity studies

1.1 Mammalian tissues and cells *in vitro*

BONES Growth factor production / sensitivity and bone tissue development *in vitro*, incultures of embryonic midfoot bones derived from mouse.

MARROW Cell differentiation *in vitro*, in cultures of bone marrow derived from mouse femur.

OBLAST Activity and proliferation *in vitro*, in cultures of osteoblast-like cells derived from rat.

FIBRO Locomotion, proliferation and cell-cell contacts *in vitro*, in fibroblast cultures derived from mouse embryos.

In BONES, MARROW and OBLAST bone formation is studied at descending levels of biological organization: organ-tissue-cell.

1.2 Insects

- CLOUD Reproduction and development in fruit flies
(*Drosophila melanogaster*).
- FLIES Behaviour, aging, reproduction and circadian
rhythm in motor activity in fruit flies
(*Drosophila melanogaster*).
- BEETLE Circadian rhythm in motor activity in
beetles (*Trigonoscelis gigas*)

1.3 Unicellular organisms

ALGAE Cell division cycle: proliferation and ultrastructure in unicellular algae (*Chlamydomonas*).

2. Radiation studies

2.1 Biological damage analyses

SEEDS Genetic radiation damage in plant seeds
 (*Arabidopsis thaliana*)

DOSICOS Radiation damage in plants (*Wolffia arrhiza*)

2.2 Dosimetry

SEEDS Track detection of ZE particles including
 protons

DOSICOS Track detection of HZE and neutrons

In SEEDS and DOSICOS, experiment packs are mounted inside as well as outside the BION 10 satellite to obtain different levels of shielding.

BIOLOGICAL PASSENGERS on BION 10

- 1 BONES Midfoot bones from embryonic mice
- 2 MARROW Marrow from murine thigh bones
- 3 OBLAST Osteoblast cell line from rat
- 4 FIBRO Fibroblasts from embryonic mice
- 5 FLIES *Drosophila* pupae, young adults
- 6 CLOUD *Drosophila* pupae, imagos, eggs, larvae
- 7 ALGAE *Chlamydomonas* zygospores, later:
free-swimming unicellular algae
- 8 SEEDS Dry *Arabidopsis* seeds
- 9 DOSICOS *Wolffia* miniature plants
- 10 BEETLE *Trigonoscelis* beetles

TRANSPORT TO MOSCOW

- Living materials and hazardous materials: Rules of flight operators (Aeroflot, KLM, Lufthansa etc) to be checked by experimenters.
- Temperature and atmosphere in freight compartment should be compatible with organisms.
- Custom clearance in Moscow : help from IBMP

ESA/IBMP laboratory in Moscow:

- Pre-Fab building
 - the same one will be used and tried-out in the Experiment Sequence Test (Jan/Feb 1992, ESTEC) Prime purpose:
 - sterile work
 - radionuclides
- IBMP laboratory
 - limited space

EXPERIMENT PREPARATION TIMELINE

Hand-over external experiments (SEEDS and DOSICOS) at L -10 days.

Hand-over internal experiments at L -3 days. (BONES, MARROW, FIBRO. OBLAST, ALGAE, FLIES, CLOUD, BEETLE, SEEDS, DOSICOS)

Activities will peak at L -4 days.

Experimenters should not leave Moscow before L (in view of a launch delay).

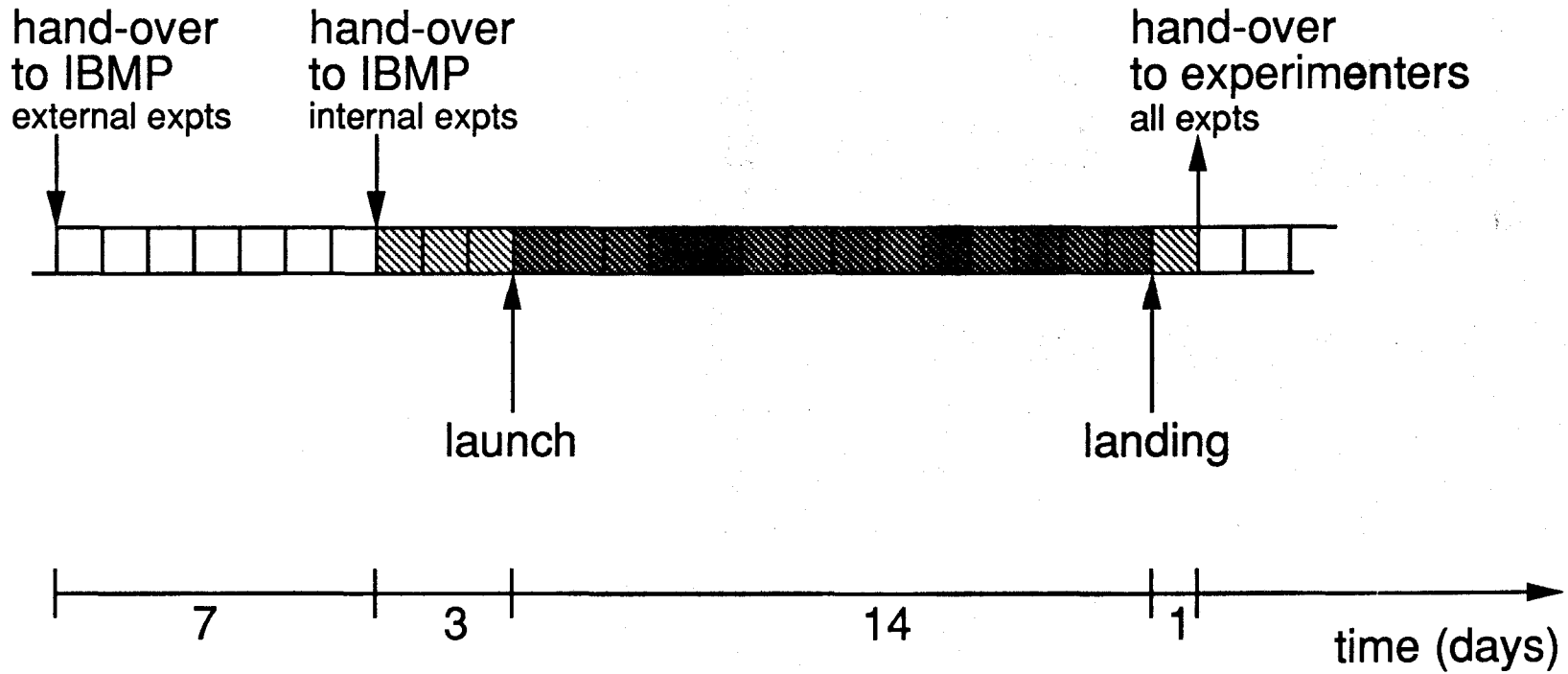

BION10 CAMPAIGN TIMELINE

BION10-1

MOSCOW MANPOWER PROFILE

BONES 4

MARROW 3

OBLAST 2

FIBRO 2

FLIES 1

CLOUD 2

BEETLE 2

ALGAE 2

DOSICOS 1

SEEDS 1

20 investigators

plus: 3 ESA members

2-3 engineers (industry)

Total approx. 25

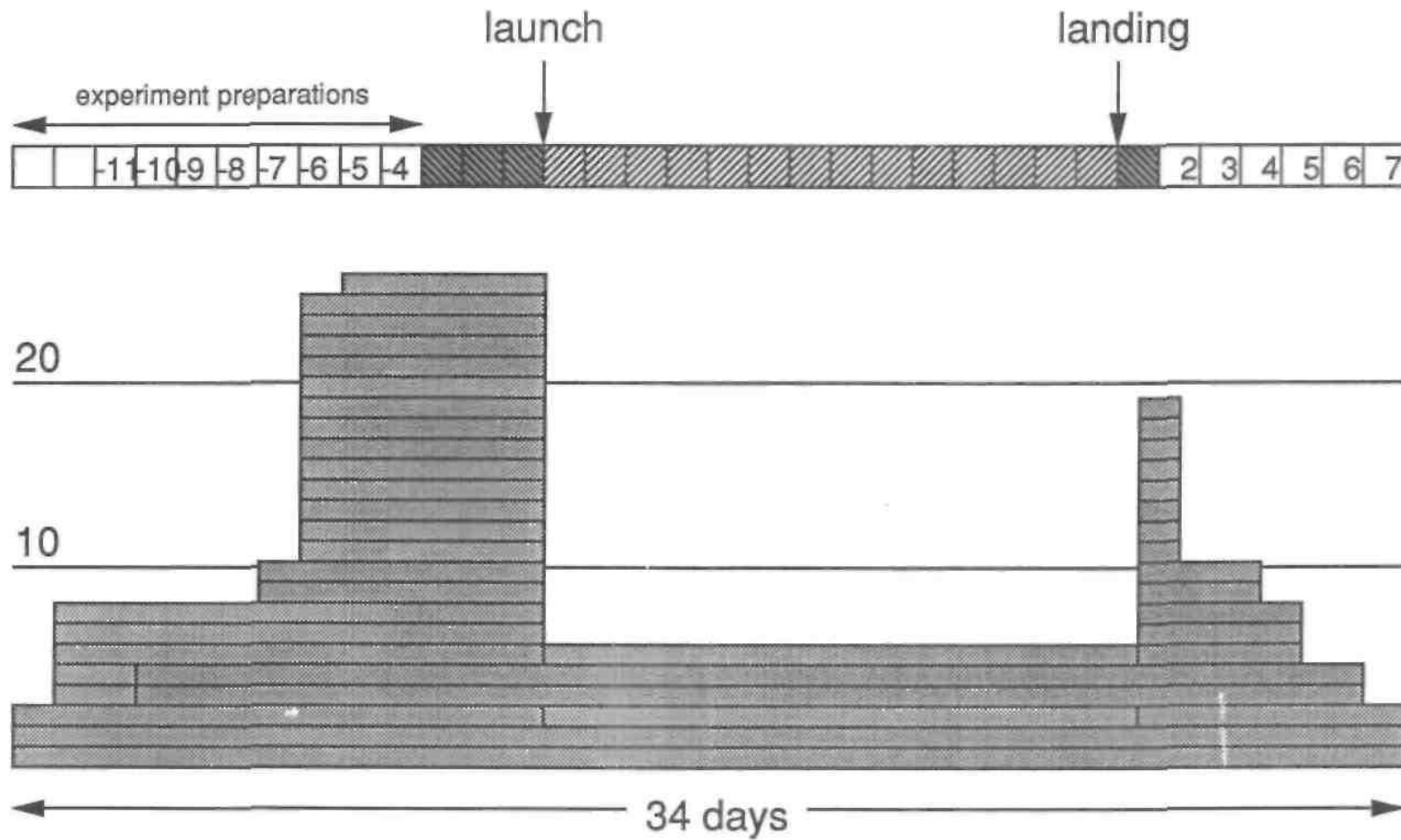

BION10

B ION 10-3

MANPOWER PROFILE

LAUNCH DATE

-Launch date to be announced by IMBP
40 days in advance.

-Planning date: 1 August 1992

ONE-WEEK LAUNCH DELAY: What to do if there is one

Repeat of preparations:

BONES

MARROW

OBLAST

FIBRO

FLIES

CLOUD

BEETLE (?)

Possibly no repeat necessary:

SEEDS

DOSICOS

ALGAE

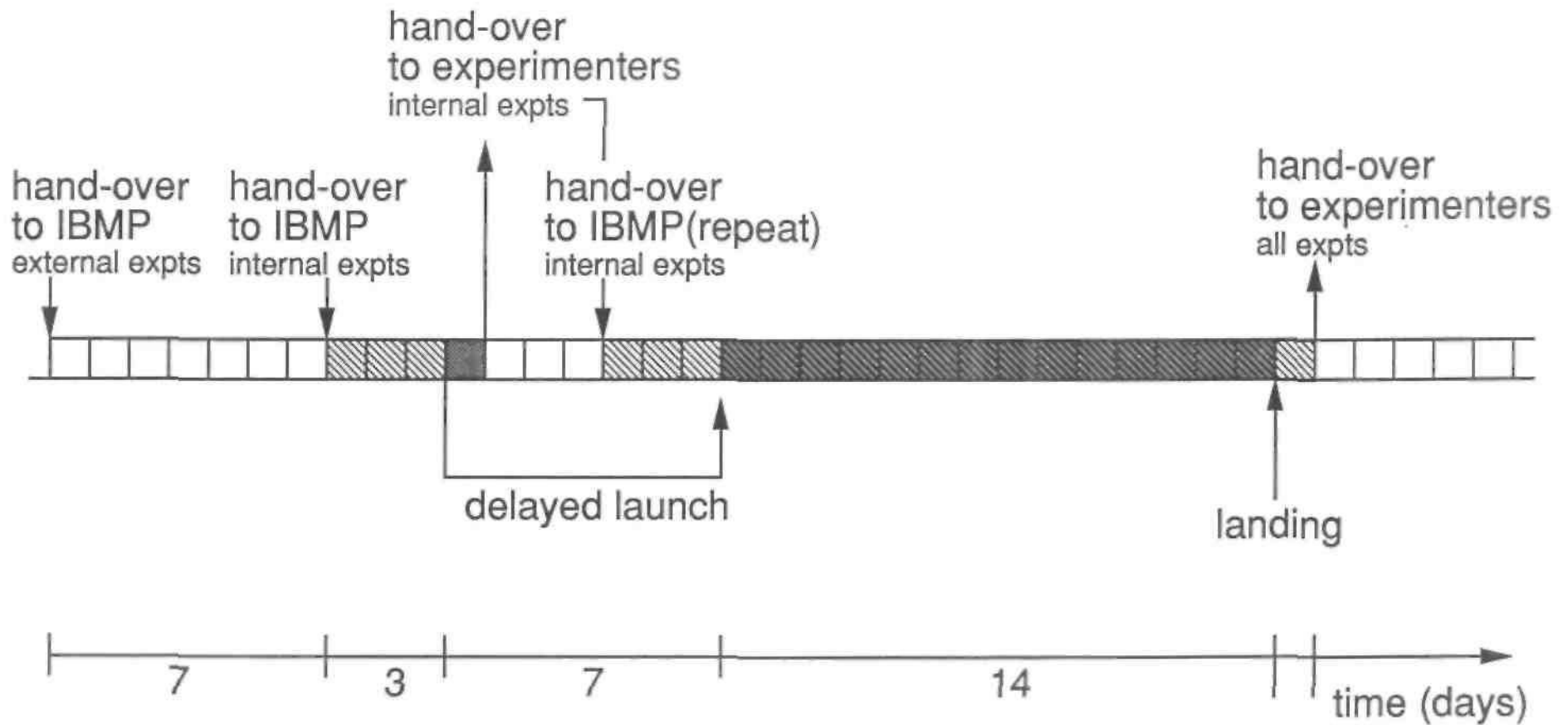

BION10 CAMPAIGN TIMELINE

BION 10-1

(1 week launch delay)

TRANSPORT TO THE COSMODROME (L -3 days)

- Moscow-Plesetsk by train (800 km) 18h?
- BONES, MARROW, OBLAST and FIBRO in BIOBOX in transport container
- All other experiments in VEBA thermoboxes at 22 °C
- Accompanied by IBMP and ESA members

EXPERIMENT INSTALLATION IN SATELLITE (L -2 days)

- BIOBOX inbetween the monkeys.
- FLIES in "BBBox"#1
- ALGAE in "BBBox"#2
- CLOUD in ?
- BEETLE in ?
- SEEDS (inside exposure) in 1 Biorack Type II container in "BB BOX" #3 ?
- SEEDS (outside exposure) in 2 Biorack Type I containers in KNA
- DOSICOS (inside exposure) in "BB BOX #3?
- DOSICOS (outside exposure) various detector packs in KNAs

BION-10 FLIGHT HARDWARE

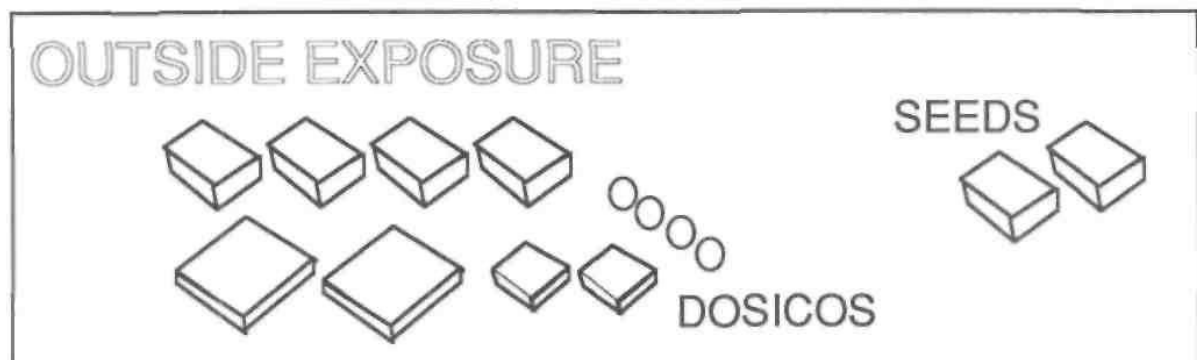
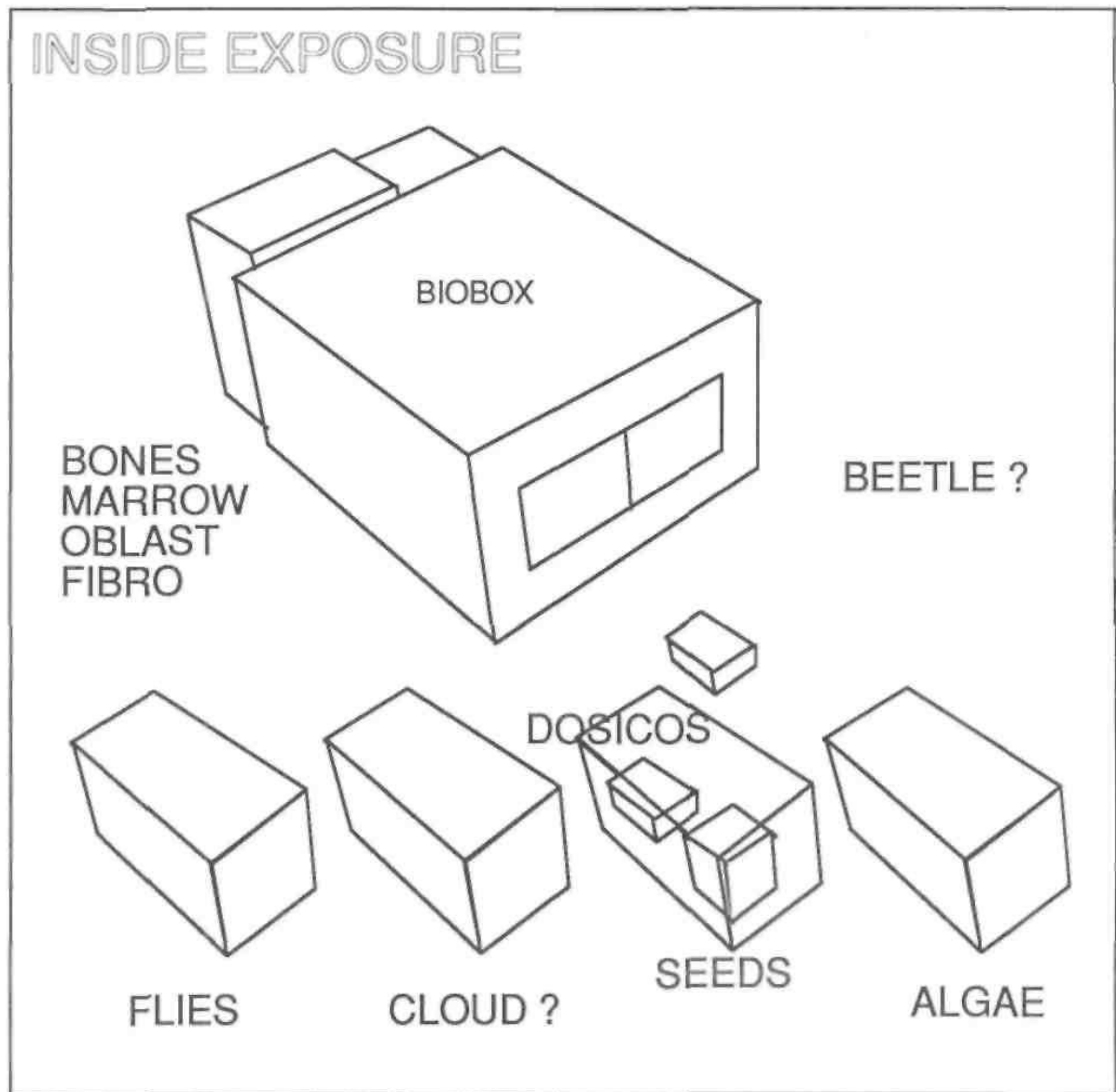

EXPERIMENT ACTIVITY TIMELINE

- BONES active during the first 6 days
- MARROW, OBLAST and FIBRO active during the first 9 days
- FLIES, CLOUD, SEEDS, DOSICOS and BEETLE active throughout the flight
- ALGAE active on days 10-11-12-13

EXPERIMENT ACTIVITY TIMELINE

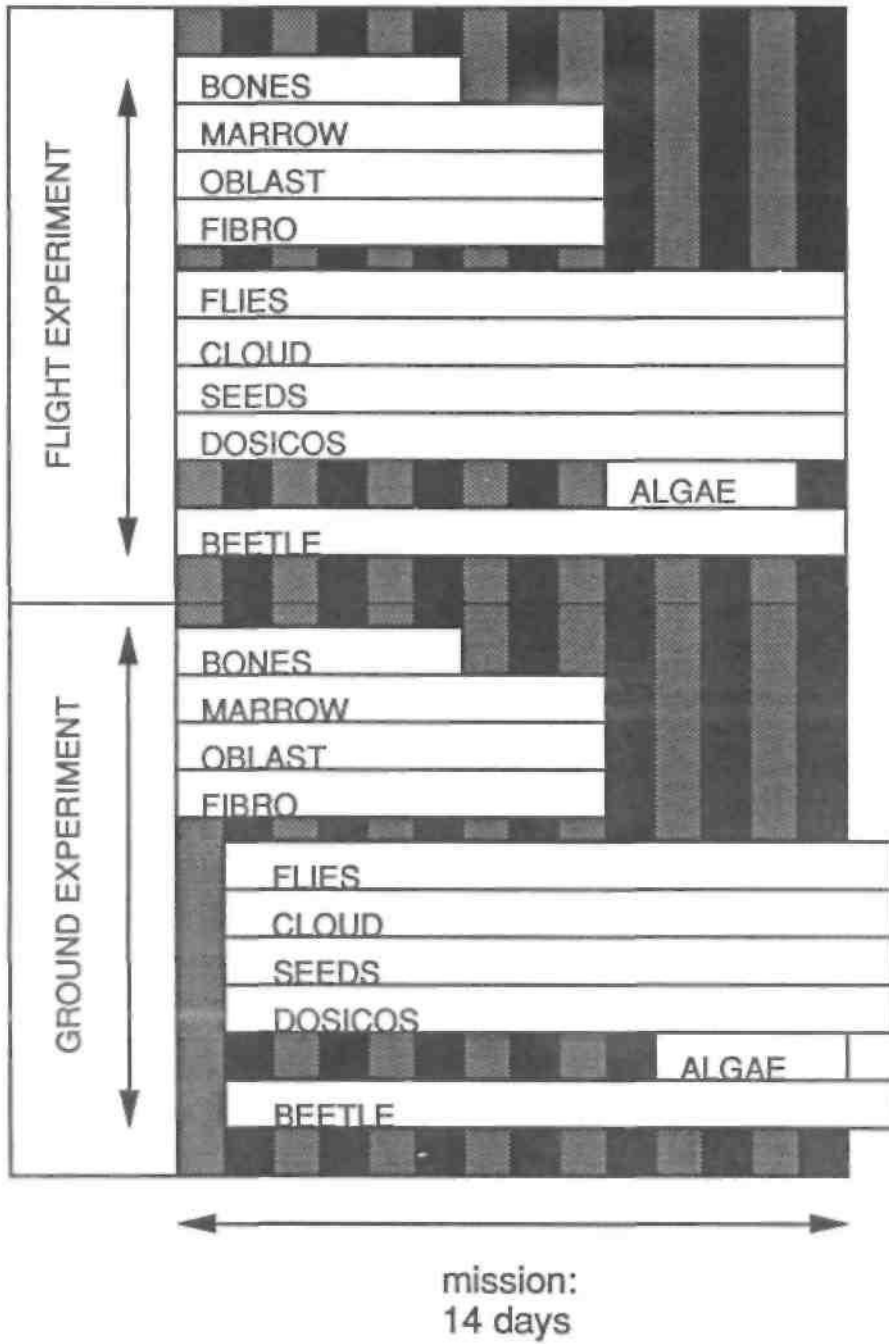

TEMPERATURE HISTORY

-Temperature history inside Biobox (BONES, MARROW, OBLAST, FIBRO) is pre-programmed in flight and on the ground

- Flight temperature history FLIES.CLOUD, SEEDS, DOSICOS, ALGAE, BEETLE is re-created on the ground. 1 day delay.

TEMPERATURE CONTROL ON THE GROUND

- 1 orbit = 90 minutes -16 orbits per day
- 8 passes per day over USSR territory
- 5 - 6 data dumps per day to telemetry stations on the ground
- blind gaps may last 16 hours
- data dump contains temperature history
- data sent to Moscow Flight Centre (20-30 minutes)
- data sent to IBMP

- flight temperature history re-created on the ground (24 h delayed)
- continual temperature adjustments on the ground required

- temperature history from L -3 to L ?

LANDING

- Satellite decelerated by rocket engine
- Battery pack, rocket motor and jettisoned.
- Payload module re-enters into atmosphere
- Parachute deployed
- Impact cushioned by small rocket
- Landing site: near Kustanaj (Kazakhstan)

POST-LANDING

- Satellite found by helicopters
- Experiments removed from satellite
- Biobox coupled to battery pack
- Other experiments in VEBA
thermoboxes + batteries
- Helicopter to Kustanaj
- Jet plane to Moscow
- Experiments back in laboratory within
24h after satellite landing

POST-FLIGHT ACTIVITIES

L +14 Landing

L + 15 Hectic day!

- Flight experiments back in Moscow laboratory
- Disassembly Biobox (flight and ground)
- Temperature data retrieval flight series FLIES, CLOUD, ALGAE, BEETLE
- Investigation FLIES, CLOUD, BEETLE
- Sample processing ALGAE (FLIGHT)
- Final day ground control expts. FLIES, CLOUD, ALGAE, BEETLE

POST-FLIGHT ACTIVITIES (continued)

BONES: Samples in plunger boxes back home.

MARROW: Samples in plunger boxes back home.

OBLAST: Samples in plunger boxes back home.

FIBRO: TBD

POST-FLIGHT ACTIVITIES (continued)

- FLIES:** Initial analysis in Moscow (3-4 days).
Stored data retrieved in Moscow.
50% of the material to Spain.
- CLOUD:** Initial analysis in Moscow (3-4 days).
50% of the material to Spain.
- ALGAE:** Sample processing in Moscow
50% to Amsterdam 50% to Leningrad
- SEEDS:** Detectors + seeds to Frankfurt
Later: seeds back to Moscow
- DOSICOS:** Detectors + Wolffia to Cologne.
Later: Wolffia flown back to Moscow.
- BEETLE** TBD

SAMPLE TRANSPORT FROM IBMP TO SHEREMETYEVO-2 (Moscow Airport)

- From ESA / IBMP laboratory to Sheremetyevo-2: about 5 min by car
- Sequence: customs, check-in, passport control. May take quite some time

Samples BONES, MARROW, OBLAST cool (4°C)
Samples ALGAE cool and frozen

SAMPLE RETURN BY AIR

- Don't store your samples in the freight compartment.
- Samples BONES, MARROW, OBLAST cool during export flight (4°C)
- Samples ALGAE cool and frozen during export flight
- refrigerator in pantry
- Not allowed to have accumulators / batteries on board

TRANSPORT FROM WEST EUROPEAN AIRPORTS TO LABORATORIA

BONES, MARROW, OBLAST cool
ALGAE cool and frozen

COOLING BOX (ESA)

- Fits in overhead storage
- Coleman cool box
- Camping Gaz cool elements (4 °C)
- temperature display
- temperature history inside and outside recorded by stick-on loggers
- Endurance: to be tested

A precursor was successfully tested on a journey Amsterdam-Moscow (herrings) and Moscow-Amsterdam (mushrooms)

CDR = Critical Design Review
EAR = Experiment Acceptance Review
EQT = Experiment Qualification Tests
EST = Experiment Sequence Test

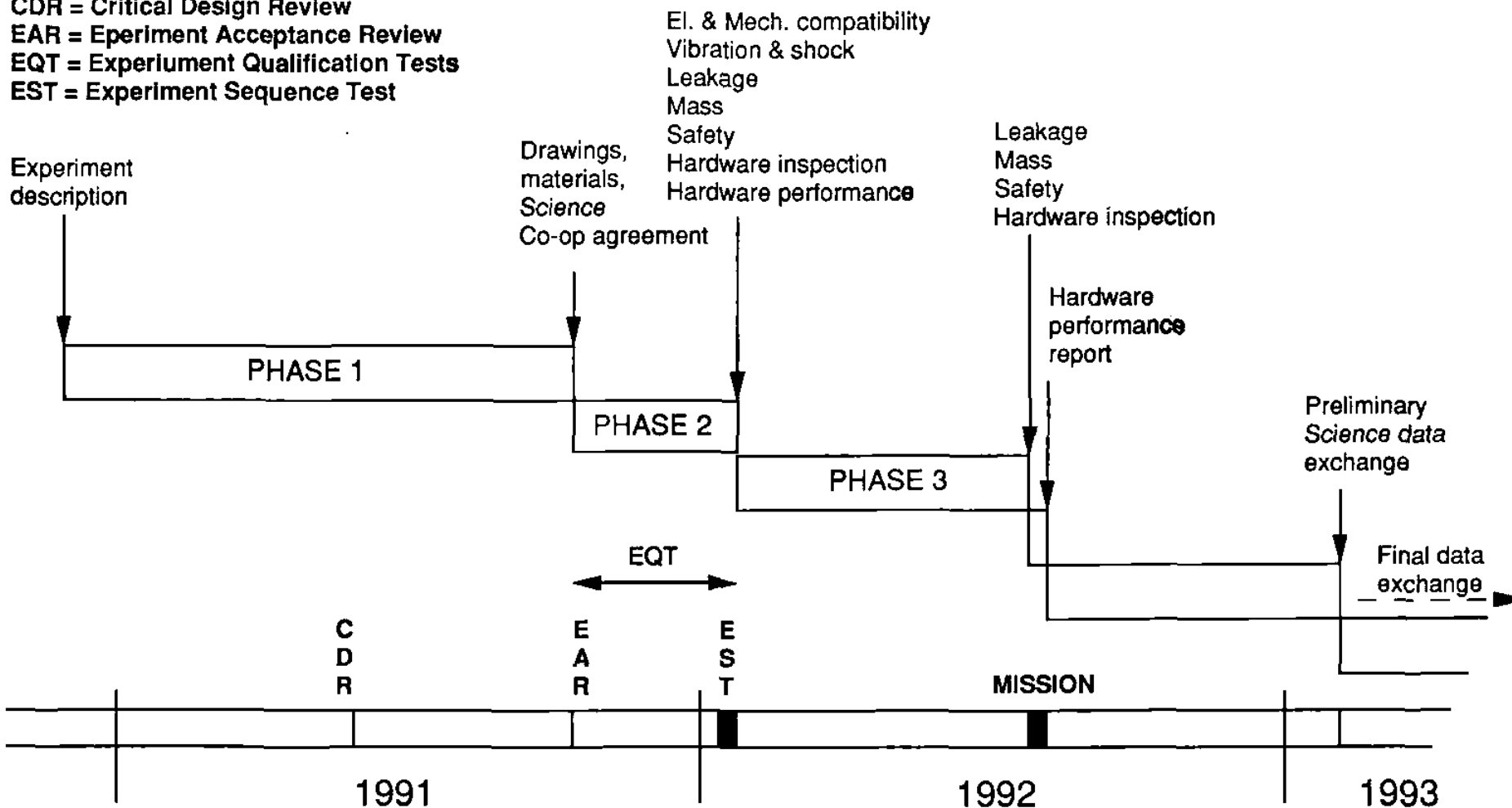

BION-10

EXPERIMENT DEVELOPMENT TIMELINE

BION-10
SCHEDULE AND PROGRAMMATIC ASPECTS

W. Jansen
Moscow, December 3-4, 1991



SCHEDULE ASPECTS

(Biobox)

Biobox

- Critical Design Review: almost completed
- Qualification Model at ESTEC for the Bion-10 Experiment Sequence Test (EST):
March 9-27, 1992
- Qualification Model (QM) delivery to ESA: May 8, 1992
- Flight Model (FM) delivery to ESA: May 18, 1992
- Flight Spare Model (FS) delivery to ESA: June 3, 1992
- Planned shipment of QM, FM, FS to IBMP: June 1992, i.e. about 5 months before
the planned launch date

BION-10 SCHEDULE AND PROGRAMMATIC ASPECTS

**W. Jansen
Moscow, December 3-4, 1991**



SCHEDULE ASPECTS

(Biobox)

Biobox

- Critical Design Review: almost completed
- Qualification Model at ESTEC for the Bion-10 Experiment Sequence Test (EST):
March 9-27, 1992
- Qualification Model (QM) delivery to ESA: May 8, 1992
- Flight Model (FM) delivery to ESA: May 18, 1992
- Flight Spare Model (FS) delivery to ESA: June 3, 1992
- Planned shipment of QM, FM, FS to IBMP: June 1992, i.e. about 5 months before
the planned launch date



SCHEDULE ASPECTS (experiments, GLE)

Bion-10 experiments

- Critical Design Review: passed
- Experiment development generally on schedule for a November 1992 launch date
- All experiments in their prototype hardware phase and approaching the Experiment Acceptance Reviews (around February 1992?)

Ground Laboratory Equipment

- Most of the equipment ordered
- Moslab development on schedule for the EST



PROGRAMMATIC ASPECTS (points requiring early clarification)

- The availability of direct dial telephone/telefax links from Moslab to Plesetsk and abroad, assuming the equipment will be made available by ESA (ref. Comstar suggestion)
- The provision of IBMP access badges to designated project personnel
- The provision of multiple-entry visa to the already designated key personnel
- The access by a limited number of project personnel to the launch site
- Agreement on the date of shipment of Moslab to IBMP; the provision to ESTEC of a drawing of the unobstructed access areas; the availability of a mobile crane for installation of the units
- Agreement on the incorporation of Biobox in the Bion-10 flight rehearsal in the satellite mock-up at IBMP

BION-10 EXPERIMENTS

R. Demets
Moscow, December 3-4, 1991



BION-10

EXPERIMENT DEVELOPMENT TIMESCHEDULE

1. Experiment definition: complete (CDR, ESTEC, May 1991)
2. Science cooperation: complete (CDR, ESTEC, May 1991)
3. Experiment hardware
 - 3.1 Manufacturing of prototype hardware: complete for each experiment
 - 3.2 Hardware design baselined: present stage, leading to the Experiment Acceptance Reviews
 - 3.3 Hardware qualification
 - 3.3.1 Vibration test: Jan/Feb 1992
 - 3.3.2 Experiment Sequence Test (ESTEC) March 1992
 - 3.4 Final hardware modifications April-Oct 1992
 - 3.5 Hardware ready for flight October 1992



BION-10

EXPERIMENT HARDWARE DEVELOPMENT PROBLEMS

BONES	biocompatibility, gas exchange
MARROW	biocompatibility, gas exchange
OBLAST	no problems; ready
FIBRO	tbd by IBMP
ALGAE	insufficient containment formaldehyde
FLIES	hardware miniaturization
CLOUD	tbd by IBMP
DOSICOS	Type 1 containers vacuum tight? Soviet part: tbd by IBMP
SEEDS	Type 1 containers vacuum tight? Soviet part: tbd by IBMP



BION-10

GROUND LABORATORY EQUIPMENT

BONES	defined (CDR, May 1991) and then ordered
MARROW	idem
OBLAST	idem
FIBRO	idem
ALGAE	idem
FLIES	idem
CLOUD	idem
DOSICOS	idem
SEEDS	not defined at CDR, not ordered



**Centrum voor
Constructie en
Mechatronica**

Duivendijk. 7, 5672 AD Nuenen
P.O. Box 12, 5670 AA Nuenen
The Netherlands

PAGE 1 OF 3 PAGES

Date: 08-12-92

Project no: 197-06-02

Our ref: Space\BIOBOX\Operations-3.fax

FROM : Ir. J.P.Leysten

Phone no: +31-40-834405

Telefacs.no: +31-40-837135

TO:

COMPANY: ESA - ESTEC

ATTN. : Mr. A.J.Knell

DEPT. : GPS

FACS.NO: 01719-17400

COPY TO : H.P.Willemsen - CCM

SUBJECT : BIOBOX - Transport CCM Equipment Launch Campaign
BION-10

Dear Art,

As discussed by phone we want to ask for ESA/ESTEC support concerning the transport of CCM equipment to and from Moscow.

On the following pages a detailed inventory list is given of the CCM Transport Box.

This equipment will be used during the Launch campaign of BION-10 and will not be exported to Russia. After the Launch Campaign it will be sent back to Nuenen.

Is it possible to prepare some accompanying travel papers which confirm the above mentioned statement for customs purposes. Please, both in english and russian language.

If any questions are left, please do not hesitate to contact me. Thank you in advance and I wish you a good flight to Moscow.

With kind regards

B,V. Ontwikkelingsmaatschappij CCM.

Hans Leysten.

Annex: CCM Equipment Inventory Checklist (2 pages)



CCM EQUIPMENT INVENTORY CHECKLIST		LAUNCH CAMPAIGN BION-10 1992-12-07, page 1/2
#	ITEM/DESCRIPTION:	REMARKS:
1	Transport Box, containing the following items:	Dimensions: 800x600x600 mm
13	TypB IE containers s/n: 037-...-048	Complete with gas-bag and valve. To be mounted on the lxx Centrifuges of BIO-BOX FM and FS Model.
25	Flight PCB'B (PETP)	To complete the BONES Experiment-units.
25	Flight PCB'a (PC)	To complete the MARROW Experiment-units.
21	Spare Flight PCB'B (6xPETPr 7xPC, 8xPSU]	All PCB'a sterilized and individually packed in laminate bags.
4	Spare Experiment-unite	As additional spare Experiment-unit: 1xBONES 2/3, 1xMARROW 2/3, 1xOBLAST/FIBRO 2/3, 1xOBLAST 1/6
1	Box containing various spare parts.	Spare parts for the ExpBrimant-unitss screws (M2.X5, M2x8, slotted + torx), O-rings, membranes + pottoms, gaskets, Bio-foils [PE]. Spare parts for the CIS-containers: shields, leaf springs, springs, O-rings, valves, caps, screws (M4x8). Spare parts for the ALGAE Experiment: screws, membranes + bottoms, gaskets, O-rings.
1	Toolbox complete with various tools.	Including: 1 pressurized screwdriver (T=0.08 Nm) 2 calibrated screwdrivers (T=0.08 Nm) 2 calibrated screwdrivers (T=2.5 Nm)
1	Soldering Equipment Set	WELLER WECP-20
2	Multi Maters	FLUKE 75
2	Workbench Clamp	BERNSTEIN
1	Spot Light	Halogene table spot light.
1	Reducing Valve with Flow Meter (max. 20 ltr/min)	GLOOR 5168; To be connected to the gas cylinder with 5% CO, supply.
1	Pluah and Vacuum Box	Including reducing valve and open/close switch, hoses and connecting nipples.
1	Pressure meter with sensor	BALZERS APG 010 and APR 016; property of ESTEC, N8: 24243
1	Vacuum Chamber	To be used for Leakage Test CIS-boxes.
1	Vacuum Pump, incl. hoses and nipples.	To be used with the vacuum chamber.



CCM EQUIPMENT INVENTORY CHECKLIST		LAUNCH CAMPAIGN BION-10 1992-12-07, page 2/2
1	ITEM/DESCRIPTION:	REMARKS:
	Labeling Machine	BROTHER PT-2000, a/n: D19252426 including Tape-cassettes (Green, Yellow, Red, Blue, White]
	Stickers, Labels	For identification of Experiment-units.
2	Personal Computers (1=spare/Backup)	To be used with the Teat-unit (CCM-GSE): TOSHIBA T1200XE + EPSON AX3s, including teat software and BACKUP's on diskettes, adapters and manuals.
1	Handheld Terminal	Two-Technology PTNR2-2/HH00909, including supply cable.
1	A.S.U. Interface Cable + RS232 Level Converter	To be used for Load/Dump Tables and Integration Test ALGAE Service Unit.
1	ACISb Interfase Cable + RS232 Level Convertor	????????? tion Test ACISbox (ALGAE).
1	Harness for LED test	To be used for Check-out LED-currents before integration ALGAE Experiment-units.
1	Dummy Exp-module Box	Including 8x Electrical dummies.
6	Spare Connectors	2x CONNECTRAL 207-09-PX-22-A001 (PTFEJ) 2x CONNECTRAL 207-09-SX-11-A001 (PTFE) 2x (HFI-150)
	Gloves, Dust-coats, Slippers.	To be used by CCM-personnel.
	DOCUMENTS: # Summary Acceptance Data Package of CIS-boxes and SCB'B. # Complete Drawing Set of the various Experiment-units. # Listing of all the files used with the generation of the Experiment Timelines. # Listing of the Experiment Timelines (*.E00 & *.C00) # Operating Procedures CCM Ground Support Equipment. # Operating Manuals CIS-box, SCB and Test-unit. # Deliverables for the Launch Campaign of BIOBOX.	

three different configurations are illustrated at the left:

- 3 experiments served by two plungers,
- 1 experiment served by six plungers,
- 2 experiments served by three plungers.

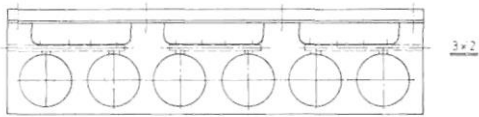

3x2

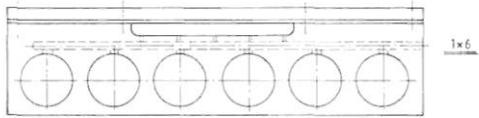

1x6

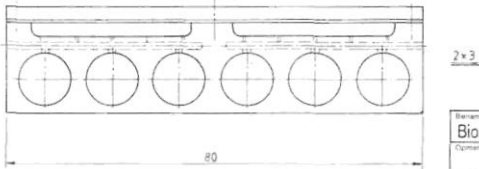

2x3

SECTION

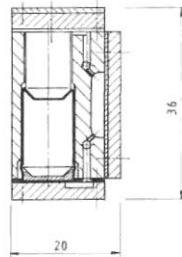



Each plunger action leads to a fluid transfer.

Rene

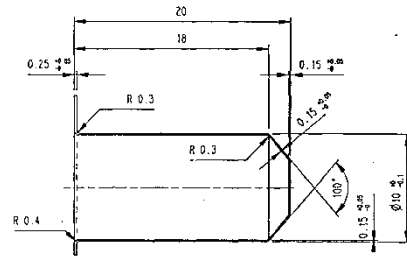
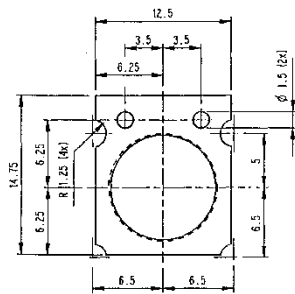
Benaming	Biorack-type, experiment unit	Get	Get	Wid	Get
Commercio		Get	13 06 90		
		Schaal	2:1		
		Get			
		Mat		Kante	
		Ren		Bew	<input checked="" type="checkbox"/>
B.V. Ontwikkelingsmaatschappij C.C.M. Duiwendijk 7, 5672 AD NUENEN Tel. 040-834405 - Telex 51890 occm nl		Formaat	A3	Stuk No	
<small>Maatregelen volgens T.B.C. en het desbetreffende tekenboek. Auteursrecht voorbehouden volgens de wet.</small>				Typ No	



Benoeming	MEMBRAAN	Get. Jy	Wjg.	Uet.
Opmerking	-	Dat.	230390	-
		Schaal	4 : 1	-
		Get.	-	-
 B.V. Ontwikkelingsmaatschappij C.C.M. Duwendijk 7, 5872 AD NUENEN Tel.: 040-834405 - Telex: 51890 occm nl	Mat.	§1 Rubber transparant	Aantal	
		Ris-X	629	Stev
Pakwijze volgens S.O. Niet aangegeven toelastbaar t 0,1 Aantal te tevens behoudbij voorgeskr. de mat	Formaat	A3		Stuk nr. Tek. nr. 00037.04.04

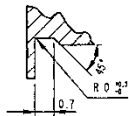
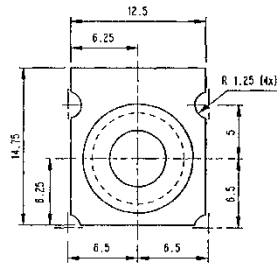
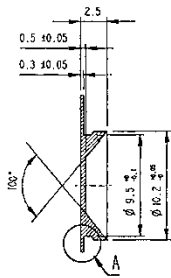

Detail A schaal 10 : 1

Benoaming	BODEM	Get. JV		Wtz.	Det.
Opmerking	-	Dui.	230390	-	-
		Schaaf.	4 : 1		
		W.C.	-		
		Mat.	81 Rubber	AKMat.	-
		R.	62	BEV.	✓
		Bel.	-		
Pijp en/of volgens ISO 15426-3 op een toerental van 0 - 1 Aantal en/of bel-bodem volgens de wett.	Materiaal AS		SNA.Nr. - Tek. Nr. 00037.04.05 /		

ESA-INTERKOSMOS LIFE SCIENCES COOPERATION

5-9 JAN. 1987 FIRST OFFICIAL MEETING ESA-INTERKOSMOS-IBMP, MOSCOW

1 APR. 1987 AGREEMENT TO FLY 2 ESA EXPERIMENTS ON BIODOSMOS 1887

8 SEPT. 1987 APPROVAL OF AGREEMENT BY INTERKOSMOS

29.9-12.10 1987 BIODOSMOS 1887 MISSION

23-27.11 1987 SECOND MEETING ESA-INTERKOSMOS-IBMP, MOSCOW

CALENDAR OF EVENTS

BIOKOSMOS 1887

- NOV 1987 . . . GROUND EXPERIMENTS (CONTROL)
- PRESENTATION OF PRELIMINARY RESULTS
- 1988 BIOKOSMOS 1887 SYMPOSIUM
- PUBLICATION OF EXPERIMENT RESULTS

ESA-INTERKOSMOS-IBMP

- ESTABLISHING OF WORKING GROUP ON SPACE MEDICINE AND BIOLOGY, MEETING 2x/YEAR
- GROUND BASED STUDIES : SUPPORT/COOPERATION
JOINT GROUND SIMULATION EXPERIMENTS
- EXCHANGE OF LITERATURE
- FURTHER AGREEMENT(S) : EACH EXPERIMENT] ?
MISSION

COOPERATIVE PROJECTS INTERKOSMOS – ESA

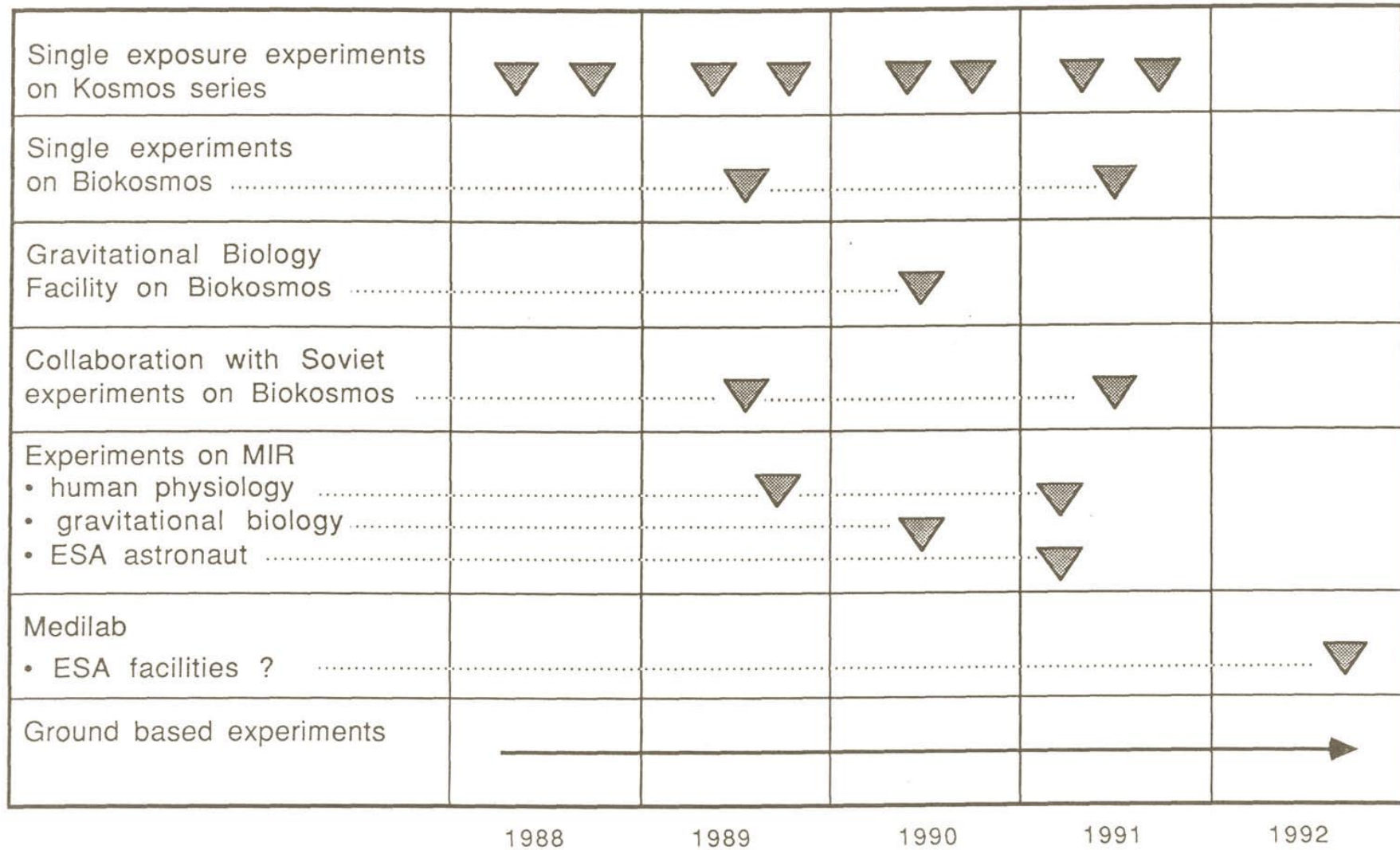

EXPERIMENT PROPOSAL IN HUMAN PHYSIOLOGY

- ENDOCRINOLOGY/
METABOLISM : ENDOCRINE RESPONSES TO MICROGRAVITY
- PRIMARY OBJECTIVE :
 - DETERMINATION OF TEMPORAL CHANGES (DYNAMICS) IN THE ENDOCRINE SYSTEM IN RELATION TO FLUID AND ELECTROLYTE HOMEOSTASIS DURING INITIAL EXPOSURE + ADAPTATION TO WEIGHTLESSNESS, AND UPON RETURN TO EARTH GRAVITY;
 - ANALYSIS EXPECTED TO DISSOCIATE DIURETIC FROM NATRIURETIC RENAL RESPONSES;
 - DEVELOP APPROPRIATE COUNTERMEASURES BASED ON UNDERLYING MECHANISMS.
- EQUIPMENT : BLOOD PLASMA (15-20 ml) AND URINE SAMPLES (24Hrs), PRE/IN/POST FLIGHT AT DETERMINED INTERVALS; 20 ml SYRINGES WITH 1 ml OF INHIBITORY SOLUTIONS; CENTRIFUGATION, STORAGE AT -20°C
- PARAMETERS T.B.D. : ATRIAL NATRIURETIC FACTOR, ANGIOTENSIN II, ANTIDIURETIC HORMONE, ALDOSTERONE, CORTICOSTERONE, 18 – HYDROXYCORTICOSTERONE

EXPERIMENT PROPOSAL IN HUMAN PHYSIOLOGY

RESPIRATORY PHYSIOLOGY : LUNG VENTILATION UNDER MICROGRAVITY

PRIMARY OBJECTIVE : PROVIDE FOR NON-INVASIVE MEASUREMENTS OF RESPIRATION PARAMETERS UNDER SHORT TERM OR LONG TERM EXPOSURE TO SPACE FLIGHT

BACKGROUND :

- **PREPARATION OF EXPERIMENTS ON ESA ANTHRORACK FOR SPACELAB MISSION D-2**
- **CONSISTENT AND ACCURATE MEASUREMENTS ON CHEST WALL CHANGES AND RESPIRATION DURING PARABOLIC FLIGHTS**

EQUIPMENT : "NON-INVASIVE" (NO MOUTH PIECE) VENTILATION PARAMETERS. MEASUREMENTS BASED ON OPTICAL SYSTEM

EXPERIMENT PROPOSALS IN HUMAN PHYSIOLOGY

NEUROPHYSIOLOGY : LONGITUDINAL STUDY OF THE CALORIC RESPONSE DURING THE COURSE OF ORBITAL FLIGHT, AND AFTER RE-ADAPTATION TO I-G ENVIRONMENT;

PRIMARY OBJECTIVE : IMPORTANCE OF THE CALORIC TEST AS AN INDICATOR FOR THE SPACE ADAPTATION SYNDROME

BACKGROUND :

- **SL-1 MISSION (END 1983), PROVE/DISPROVE THERMOCONVECTIVE THEORY; RESULTS : 2 SUBJECTS (CALORIC NYSTAGMUS)**
- **D-1 MISSION (END 1985), CONFIRMED CALORIC NYSTAGMUS, RULE OUT POSSIBLE SOURCES OF ERROR : 3 SUBJECTS CALORIC NYSTAGMUS → NON - THERMOCONVECTIVE THEORY, INDICATING OTOLITH-CANAL INTERACTION**
- **LONGITUDINAL STUDIES OF BOTH MISSION RESULTS INDICATE ADAPTATION IN RESPONSE INTENSITY OVER THE FIRST FEW DAYS OF FLIGHT, AND READAPTATION AFTER LANDING; THUS CALORIC RESPONSE MIGHT PROVE TO BE USEFUL INDICATOR FOR SPACE ADAPTATION SYNDROME**

SCIENTIFIC OBJECTIVES

- **EXAMINE FEASIBILITY OF CALORIC RESPONSE FOR VESTIBULAR ADAPTATION IN OG; EXAMINE VERY EARLY INFLIGHT (FIRST 2/3 DAYS)**
- **INVESTIGATE INTERACTION IN THE CENTRAL VESTIBULAR SYSTEM ARISING FROM COMBINED STIMULATION OF SEMICIRCULAR CANALS AND THE PROPRIOCEPTIVE OR OTOLITH RECEPTORS**

EQUIPMENT :

- **MULTICHANNEL PREAMPLIFIERS AND PCM CODER**
- **ELECTRODE KIT (FOR EOG)**
- **CALORIC STIMULATION ASSEMBLY**
- **3-AXIS ACCELEROMETER**
- **CCD VIDEO CAMERA AND MINIATURE TV MONITOR FOR EYE IMAGE RECORDING**
- **VIDEO RECORDER FOR CAMERA, PCM AND VOICE SIGNALS**
- **ANCILLARY EQUIPMENT :**
 - **ELECTRODE CHECKOUT MINISCOPE**
 - **FRENZEL GOGGLES**

TYPICAL EXPERIMENTAL PROCEDURE

- **UNSTOW EQUIPMENT**
- **ELECTRODE SUBJECT**
- **DON HELMET SUPPORTING VIDEO CAMERA, PRE AMPS AND CALORIC EARPIECE**
- **CONNECT ELECTRODES AND CHECK SIGNALS**
- **SWITCH RECORDER ON**
- **RECORD EYE MOVEMENT CALIBRATION**
- **INSERT EARPIECE OF CALORIC ASSEMBLY**
- **STIMULATE EAR FOR 1-2 MINUTES**
- **WHEN RESPONSE CLEARLY PERCEPTIBLE/OBSERVABLE**
 - **OBSERVE/RECORD FOR 1 MINUTE WITH SUBJECT FIXED**
 - **OBSERVE/RECORD FOR 1 MINUTE WITH SUBJECT FREE FLOATING**
 - **OBSERVE/RECORD WITH SUBJECT BEING LINEARLY ACCELERATED**
IN X-AXIS (USE OF BRS) : ONLY IF 2 CREW AVAILABLE
- **END EXPERIMENT / STOW**

ESTIMATED DURATION :30 MINUTES



Oblast 2-3

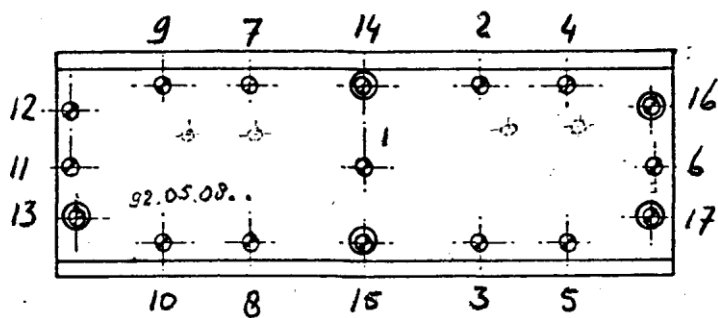
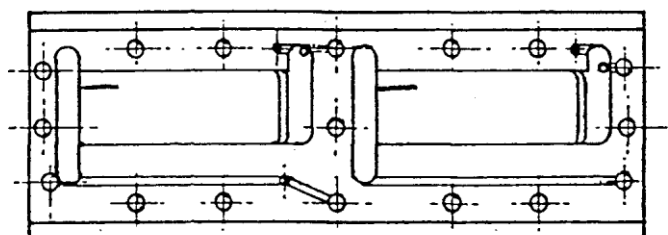

Plastic bags of polyethylene, 65 μ made by

Jydsk Teknologisk Institut
Marselisboulevard 135
DK-8000 Aarhus C
Denmark

according to the technical specifications for the polyethylene sheet

Lotrene FE 8000
CDF Chimie E.P.
SATRAP Assistance Technique
B.P. 9
62670 Mazingarbe
France

LOTRENE

FE8000

POLYÉTHYLÈNE RADICALAIRE

qualités disponibles

- **LOTRENE FE 8000** : sans agent glissant ni antibloquant.
- **LOTRENE FE 8002** : avec agent glissant.

caractéristiques d'identification

Propriétés	???	????	???
• Indice de fluidité (190°C-2,160 kg)	0,8	g/10 mn	NFT 51-016
• Masse volumique (23°C)	0,924	g/cm ³	NFT 51-063
• Température de ramollissement VICAT	99	°C	NFT 51-021 Méth. A

description

Les **LOTRENE FE 8000 - FE 8002** sont principalement destinés à l'extrusion de films.

Le **LOTRENE FE 8000** ne contient ni agent glissant, ni additif antibloquant.

La formulation du **LOTRENE FE 8002** permet la réalisation de films glissants sans phénomène d'adhérence des gaines.

La structure moléculaire de ces **LOTRENE** confère aux films de bonnes propriétés optiques et d'excellentes propriétés mécaniques.

Les films obtenus présentent la rigidité nécessaire au passage sur les machines de façonnage automatique.

La force de serrage élevée, les retraits facilement équilibrés et la transparence du **LOTRENE FE 8000** en font une qualité appréciée dans le domaine du film rétractable moyen.

Les épaisseurs réalisables industriellement sont comprises entre 25 microns et 100 microns, dans les conditions classiques de mise en œuvre.

applications

- FILMS THERMORÉTRACTABLES MOYENS ET MINCES.
- Films pour fardelage, films pour routage.
- FILMS POUR EMBALLAGE AUTOMATIQUE.
- SACHERIES EN TOUTES ÉPAISSEURS.
- Sacs petites et moyennes contenances - sacheries pour bonneterie et textile
- saches de groupage - sacs cabas.
- FILMS POUR CONTRECOLLAGE.
- FEUILLES DE PROTECTION.
- SOUFFLAGE DE CORPS CREUX.



CdF Chimie E.P.
CdF Chimie Ethylène et Plastiques

mise en oeuvre

Les LOTRENE FE 8000 - FE 8002 sont facilement transformables sur toutes les extrudeuses. Compte tenu de son indice de fluidité, la température du polymère à la sortie de la filière doit être de l'ordre de 180 à 210°C Pour éviter un bloquant, la température de la gaine au niveau du pincage doit être maintenue le plus près possible de la température ambiante.

caractéristiques

Caractéristiques du polymère?	???	????	???
• Indice de fluidité (190°C/2,16 kg)	0,8	g/10 mn	NFT 51-016 (80)
• Masse volumique (23°C)	0,924	g/cm ³	NFT 51-063 (71)
• Température de fusion	112	°C	NFT 51-621 (75)
• Température de ramollissement Vicat	99	°C	NFT 51-021 (67) (1) (Méthode A)
• Contrainte au seuil d'écoulement	10,5	MPa (2)	NFT 51-034(68)(1)
• Contrainte à la rupture	16,0	MPa (2)	NFT 51-034(68)0
• Allongement à la rupture	560	%	NFT 51-034 (68)0
• Module d'élasticité en flexion	360	MPa (2)	NFT 51-001 (72)0
Caractéristiques sur film (3)	???	????	???
Épaisseur	30 50	microns	
Sens de la mesure	L T L T		
• Contrainte au seuil d'écoulement	- 11,5 - 11,0	MPa (2)	NFT 54-102 (71)
• Contrainte à la rupture	25,5 23,0 27,0 23,0	MPa (2)	NFT 54-102 (71)
• Allongement à la rupture	350 600 490 600	%	NFT 54-102 (71)
• Résistance au déchirement	200 180 280 280	g	ASTM D 1922 (78)
• Module sécant à 1 % d'allongement	170 210 160 180	MPa (2)	NFT 54-102 (71)
• Résistance à l'impact	100 150	g	NFT 54-109 (73)
• Coefficient de frottement			
FE8000	0,60 0,60	—	NFT 54-112 (80)
FE8002	0,15 0,12	—	
• Perméabilité à la vapeur d'eau	15 12	g/cm ² -24 h	NF H 00030 (74)
• Perméabilité à l'oxygène	17500 12000	cm ³ /m ² - 24 h-atm	Méthode interne
• Perméabilité à l'azote	5500 3500	cm ³ /m ² -24h-atm	Méthode interne
• Trouble	7,5 7	%	NFT 54-111 (71)
• Brillance (60°)	95 100	—	ASTM D 2457 (77)

(1) Éprouvette moulée par compression selon ISO 293 (74).

(2) 1 MPa = 10.2 kg/cm²

(3) Sur film extrudé au taux de gonflage 2:1.

NOTA : Les valeurs indiquées ci-dessus peuvent servir de guide a ('utilisation du produit et ne doivent être considérées ni comme des limites de spécifications, ni comme des garanties.

REMARQUE : Les **LOTRENE FE 8000 - FE 8002** sont conformes aux réglementations en vigueur dans la plupart des pays concernant ('utilisation au contact des denrées alimentaires.



CdF Chimie E.P.
CdF Chimie Ethylène et Plastiques

DIRECTION DES THERMOPLASTIQUES

Tour Aurore Cedex n° 5 - 92080 PARIS DÉFENSE 2 - FRANCE
Tél : (1) 47.78.51 51 - Télex : 610826 F

ASSISTANCE TECHNIQUE SATRAP

BP 9 - 62670 MAZINGARBE
Tél. : 2172 92 33 -Télex 120142 F

**FICHE
TECHNIQUE**
10/85 Z 51/2

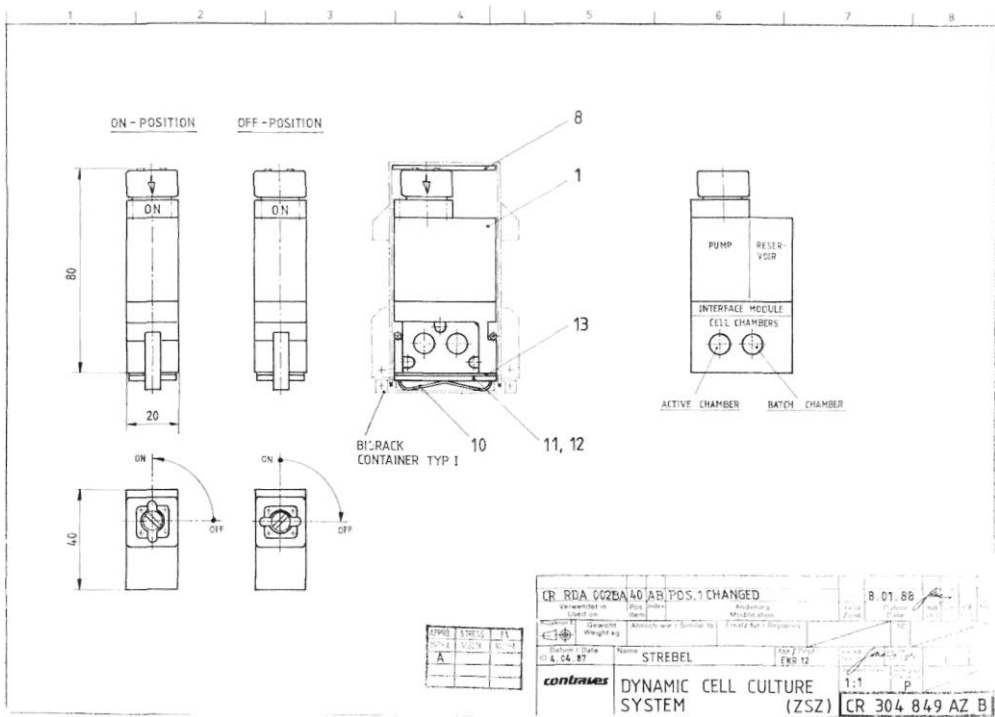

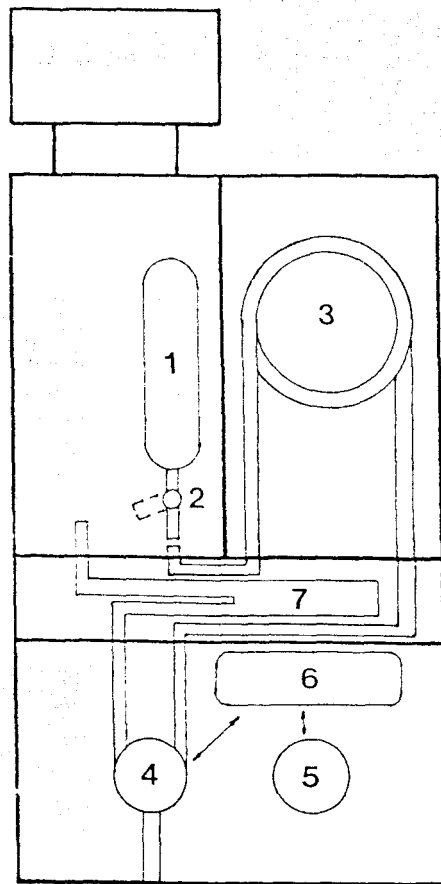



- 1 OSMOTIC PUMP
- 2 VALVE
- 3 MEDIUM RESERVOIR
- 4 ACTIVE CHAMBER
- 5 BATCH CHAMBER
- 6 GAS CHAMBER
- 7 WASTE RESERVOIR

FIGURE 2.12-1 DYNAMIC CELL CULTURE CHAMBER (DCCC)

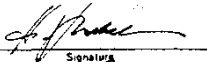
**MATERIAL-LIST FOR
DYNAMIC CELL CULTURE SYSTEM
FLIGHT MODEL**

<i>Prepared by :</i>	H. Strebel	 <small>Signature</small>	Oct. 88
	_____	_____	<small>Date</small>
<i>Reviewed by :</i>	W. Bussmann	<i>W. Bussmann</i> <small>Signature</small>	Oct. 88
	_____	_____	<small>Date</small>
<i>Approved by :</i>	R. Danz	 <small>Signature</small>	Oct. 88
	_____	_____	<small>Date</small>
<i>Approved by :</i>	_____	_____	<small>Date</small>

Distribution : **???** **2x**

CONTRAVES: **R. Danz**
 H. Strebel
 W. Bussmann

DOCUMENT CHANGE RECORD

Rev.	Page	Date	Document Changes	Approval
1	all	Oct. 88	Initial issue	

Codes used:

Size code		
2 Area, cm ²	volume, cm ³	Weight, g
A1 0 - 10	VI 9 - 1	W 1 0 - 1
A2 11 - 100	V2 2 - 50	W2 2 - 50
A3 101 - 1000	V3 51 - 500	W3 51 - 500
A4 > 1000	V4 > 500	W4 > 500

Environment:

Radiation		Pressure		Temperature	
Outside in sunlight	R ₁	Space vacuum	P ₁	0-250 K	T ₁
Outside in shadow	R ₂	Pressurised < 1 atm	P ₂	250-350 K	T ₂
Inside spacecraft	R ₃	Pressurised > 1 atm	P ₃	> 300 K	T ₃

No.	Commercial Identification	Chem Nature, Type of Prod.	Procurement Information	Summary of Process. Para	Use and Location	Environment Code	Size Code	Status
	Anticorodal	AL Mg Si 1 Mn/TG WN 3.2315 72	Alusuisse CZ-Zuerich	machined, anodized	Structural parts	R ₃ , P ₂ , T ₂	W ₂	
	Stainless Steel	X 2 Cr Ni Mo 18 12 WN 1.4435	Boehler Stahl AG CH-Zuerich	machined, passivated ace. CZ-NO. CR 407 984A\ Teflon coated acc. Buser-No.: 384.940.1000.9.84	Structural parts: - Cell Chamber - Pump Houscing - Pump Cylinder	R ₃ , P ₂ , T ₂	W _{2,3}	
	Stainless Steel	X 12 Cr Ni 17 7/K WN 1.4310-8	v.D.G. D-Hamm	machined, thermal treatment (400° C/1H)	Spring for Fixation	R ₃ , P ₂ , T ₂	W ₂	

MATERIALS LIST
Type

No.	Commercial Identification	Chem. Nature Jype of Prod.	Procurement Information	Summary of Process. Para	Use and Location	Environment Code	Size Code	Status
	Silicone	Sil 80 MVQ 80,5	Angst + Pfister CH-Zuerich	-	Sealing Ring	R ₃ P ₂ T ₂	W ₁	
	Silicone	MQ	Angst + Pfister CH-Zuerich	machined	- Sealing - Damper	R ₃ P ₂ T ₂	W ₁	
	Viton	FPM SH 75 A	Angst + Pfister CH-Zuerich	machined	- Sealing for Interface Module - Sealing Ring	R ₃ P ₂ T ₂	W ₁	
	Tef1 on	PTFE, white WS 7.4100	Angst + Pfister CH-Zuerich	machined	- Sealing Plate	R ₃ P ₂ T ₂	W ₁	
	Neoprene Cell Caoutchouc	PRENA	Gummi Maag CH-Zuerich	machined	- Damper Plate	R ₃ P ₂ T ₂	W ₁	
	Teflon	PTFE 461 721 (Du Pont 959-201)	Buser AG CH-Wiler		- Cell Chamber Block - Interface Module	R ₃ P ₂ T ₂	W ₁	

MATERIALS LIST
Type

No.	Commercial Identification	Chem. Nature; Type of Prod	Procurement Information	Summary of Process. Para	Use and Location	Environment Code	Size Code	Status
	Screw X 12 Cr Ni 18-8 (WN 1.4305)	CZ-No. N 3052 ... X N 3054 ... X	Bossard AG CH-Zug		Fixing	R ₃ P ₂ T ₂	W _{1/2}	
	Screw Counter sunk head X 12 Cr Ni 18-8 (WN 1.4305)	CZ-No. N 3111 ... X	Bossard AG CH-Zug		Fixing	R ₃ P ₂ T ₂	W ₁	
	Headless Screw X 12 Cr Ni 18-8 (WN 1.4305)	CZ-No. N 3201 ... X	Bossard AG CH-Zug		Fixing	R ₃ P ₂ T ₂	W ₁	
	Heli-Coil Mid-Grip Cu Sn 6 (WN 2.1020)	CZ-No. C 3474 ... B	Kisling AG CH-Zuerich		Threaded Insert	R ₃ P ₂ T ₂	W ₁	
	Washer X 12 Cr Ni 18-8 (WN 1.4305)	CZ No. N 3502 ... X	Bossard AG CH-Zug		Fixing	R ₃ P ₂ T ₂	W ₁	
	Curved Washer X 12 Cr Ni 18-8 (WN 1.4305)	CZ No. N 3544 ... X	Bossard AG CH-Hug		Fixing	R ₃ P ₂ T ₂	W ₁	
	Tension Pin X 12 Cr Ni 17 7/K (WN 1.4310)	CZ No. N 3570 ... X	Bossard AG CH-Zug		Positioning	R ₃ P ₂ T ₂	W ₁	

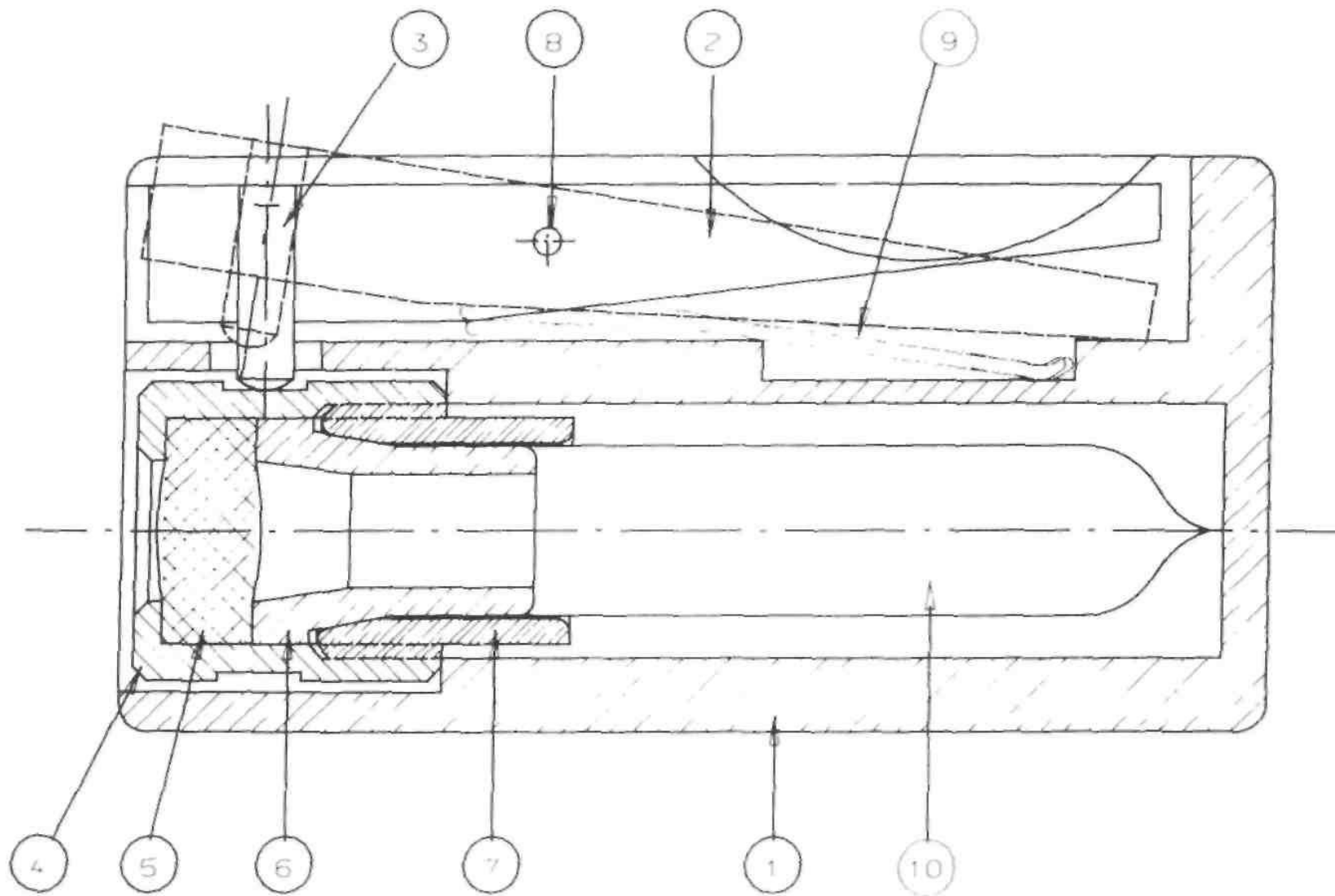

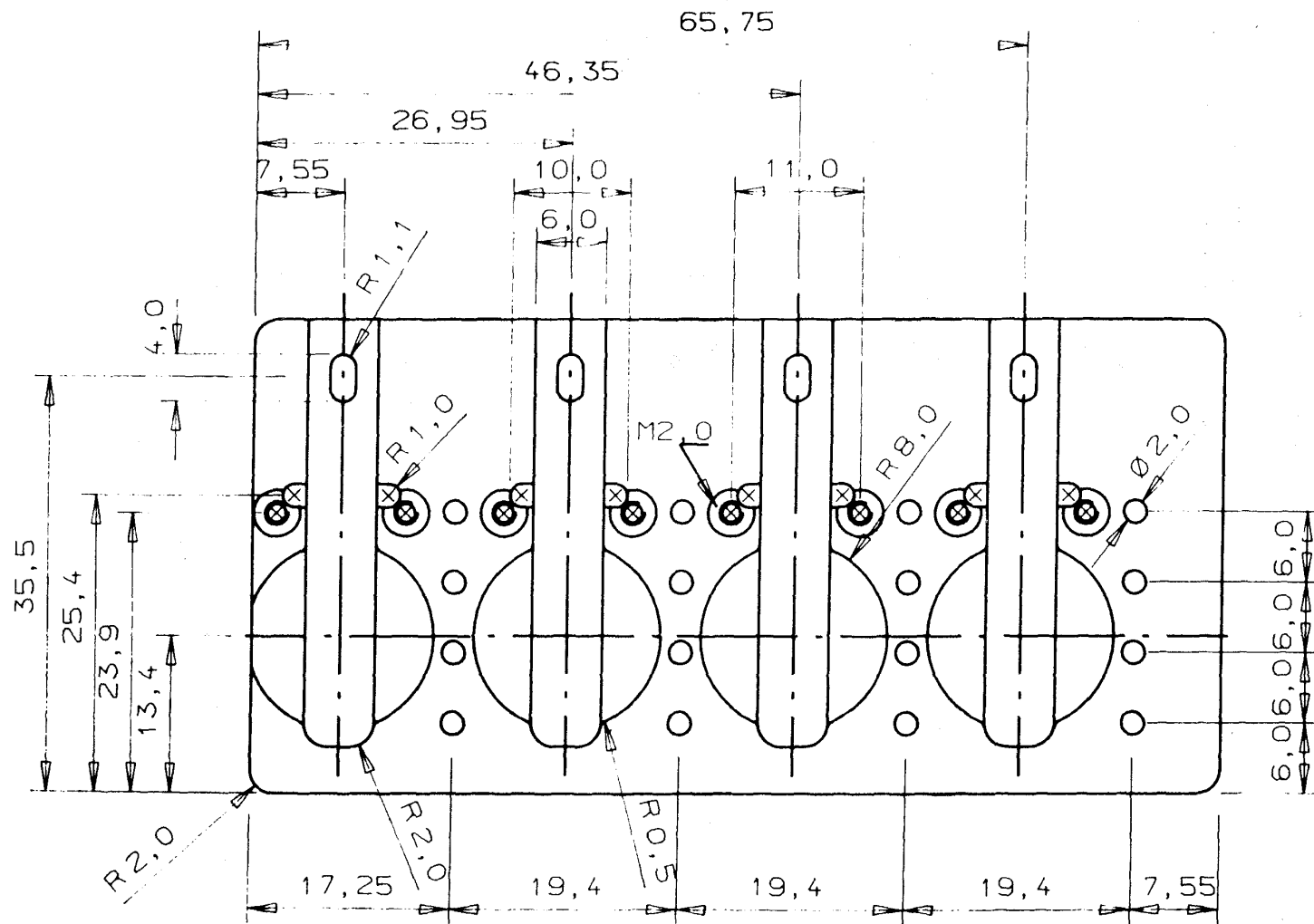

SIDE 1

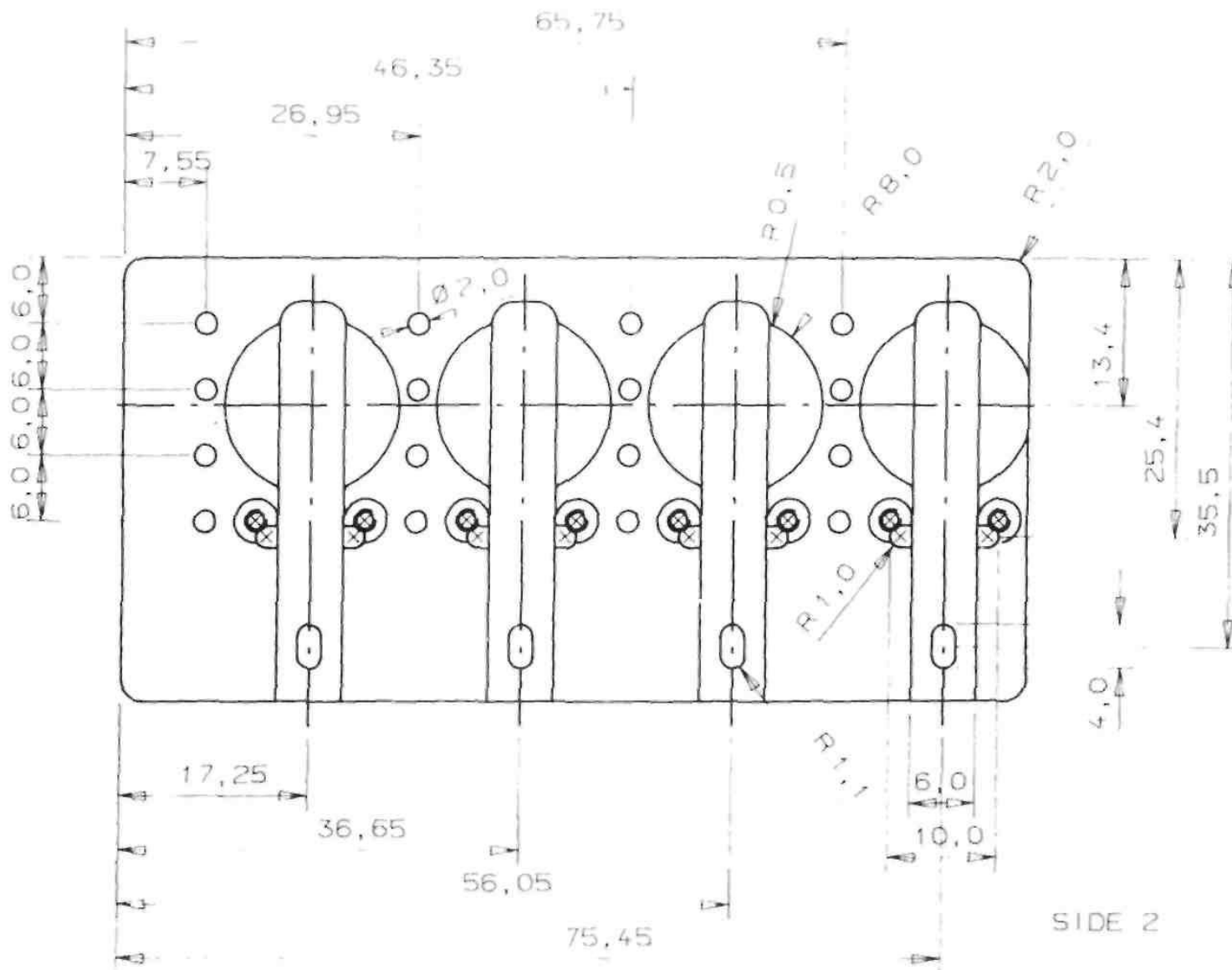

5. BIOKOSMOS 9 EXPERIMENT CONFIGURATION SHEET

5.5. EXPERIMENT NAME: SEEDS

INVESTIGATORS

ESA: A.R.Kranz, U.Bork, E.Schopper,
J.U.Schott, .Ganssauge

IBMP: V.E.Dudkin,

Exp.Unit i/d	H/W Type (drawing)	Trans- port	Contents	
			Biological	Chemical
SEEDS 1	BR Type II drawing attached	deg C 22	2250 seeds Enkhaim diploid 250 per subset 3 subsets/sheet 2250 seeds Enkhaim tetraploid 250 per subset 3 subsets/sheet Total of 6 subsets/sh Total of 3 sheets (2+1*)	6 AgCl detec- tors/sheet LiF detectors
SEEDS 2 #	BR Type I drawing attached	22	1250 seeds Enkhaim diploid 250 per sheet 1250 seeds Enkhaim tetraploid 250 per sheet Total of 500 seeds/sh Total of 5 sheets (4+1*)	Emulsion on glass Total 5 layers **
SEEDS 3	idem	22	idem Total of 5 sheets (2+3*)	idem Total 5 layers **

All containers are filled with Argon (1 atm)

* For analysis by IBMP investigators

** Analysis by IBMP investigators, preferably in Germany.

To be mounted on exposure facility.

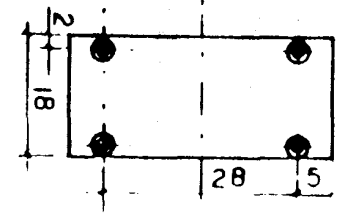
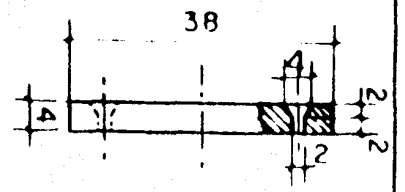
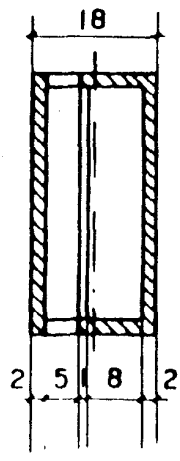
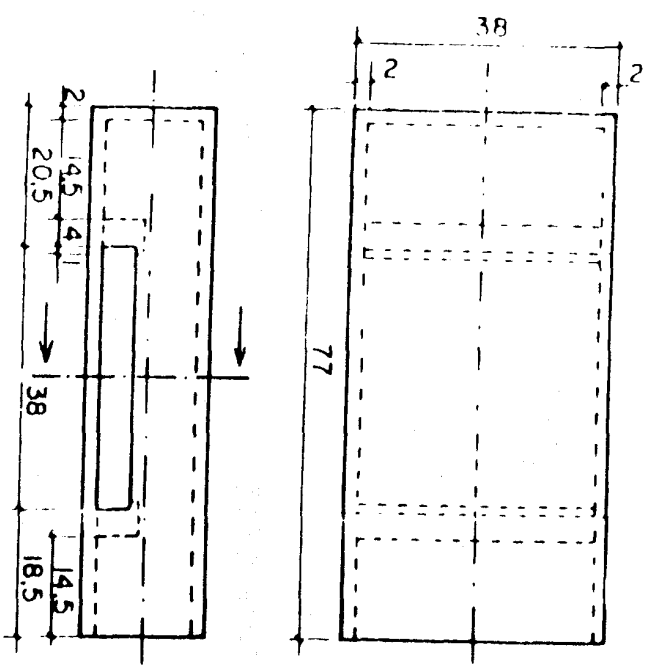
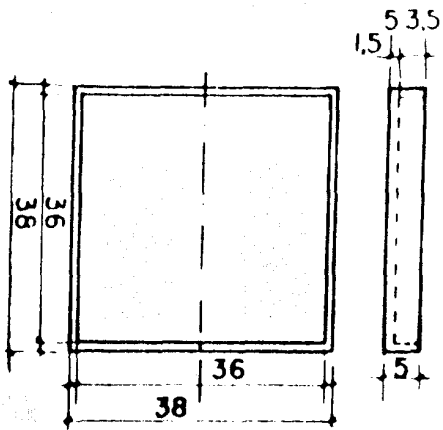

MATERIALS LIST

SPACECRAFT
SYSTEM/EXPERIMENT
CONTRACTOR

Spacelab IML-1
Biorack - 07E (FLY) DATE **12-5-87**
Dr. R. Marco Univ Madrid

No	Commercial Identification	Chemical Nature & Type of Product	Procurement Information	Summary of Processing Parameters	Use and Location	Environment code (s)	Size Code	Status & Reference
1.	Makrolon	Thermoplastic bis-xenol A polycarbonate	Bayer	Heat bent and glued Non flammable	Construction of experimental containers	R ₃ P ₂ T ₂		A ₂ V ₂ W ₂
2.	Superglue-3 (Loctite)	alkyl α-cyanoacrylate monomery with addition of metacrylate	Loctite Europa (BU) Ireland	Non flammable	Construction of experimental containers	R ₃ P ₂ T ₂		V ₁
3.	ORBASIL	Silicone sealer (Mastic silicone)	Quilosa (Coslada)		Fixation of the side cover to type I containers	R ₃ P ₂ T ₂		V ₁
4.	Fixing clips	Inoxidazable Steal	Aceros Boxaren (Leganes)		Fixation of collecting trays to experimental containers and to the spare trays containers	R ₃ P ₂ T ₂		A ₁
5.	Screws	Inoxidable Steal	Aceros Boxaren (Leganes)		Fixation of experimental and spare trays containers to the type I containers	R ₃ P ₂ T ₂		W ₁
6.	Mistol	Cleaning agent	Henkel		Washing of containers and trays	R ₃ P ₂ T ₂		V ₁

Definition of Biological Specimen and Related Chemicals

c) Solid Culture Medium

TYPE	AMOUNT/NUMBER	REMARKS
Agar	1.1% by weight	Gelling agent
Sucrose	10% concentration by weight	Carbon source
Yeast extract	10% concentration by weight	Nutrient
Propionic acid	0.6% concentration by volume	(individual weights per tray is TBD)
Methyl P-Hydroxy-benzoate	0.12% concentr. by volume	

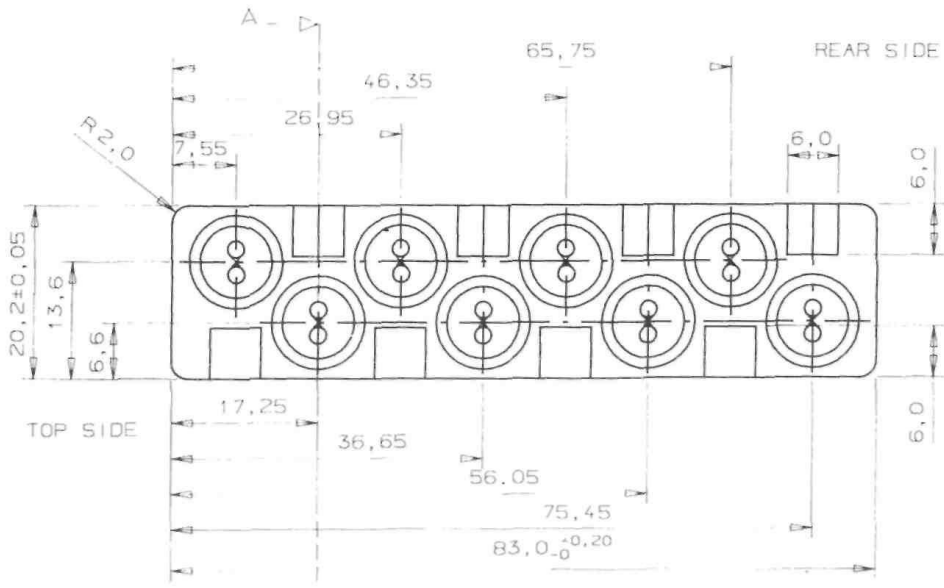
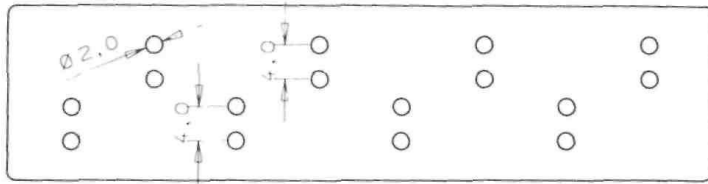

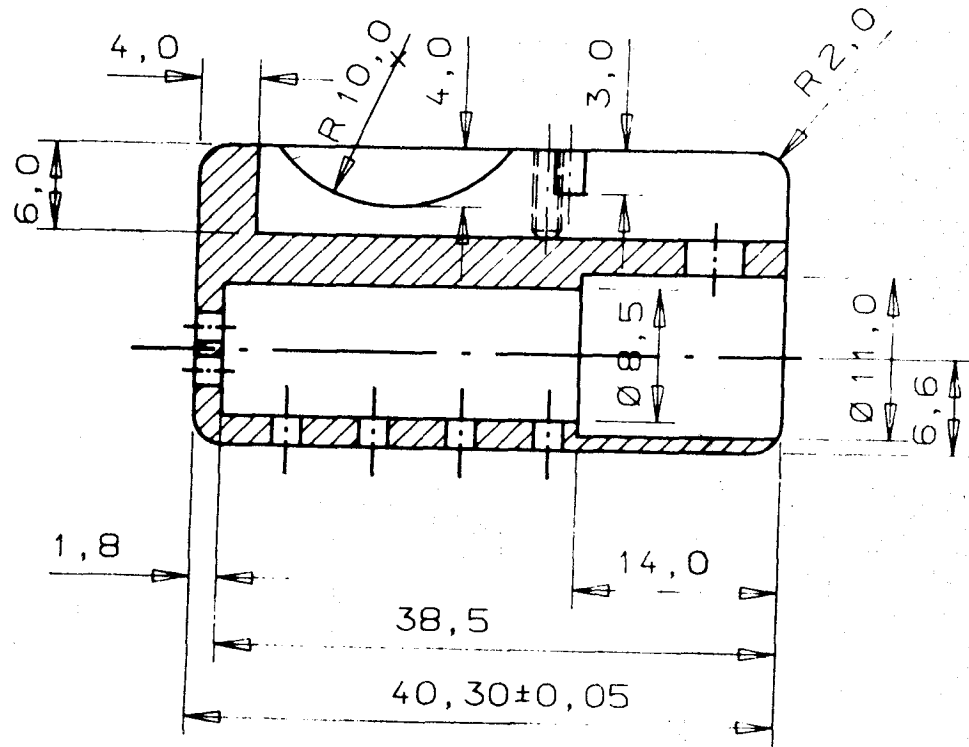

SECTION A-A

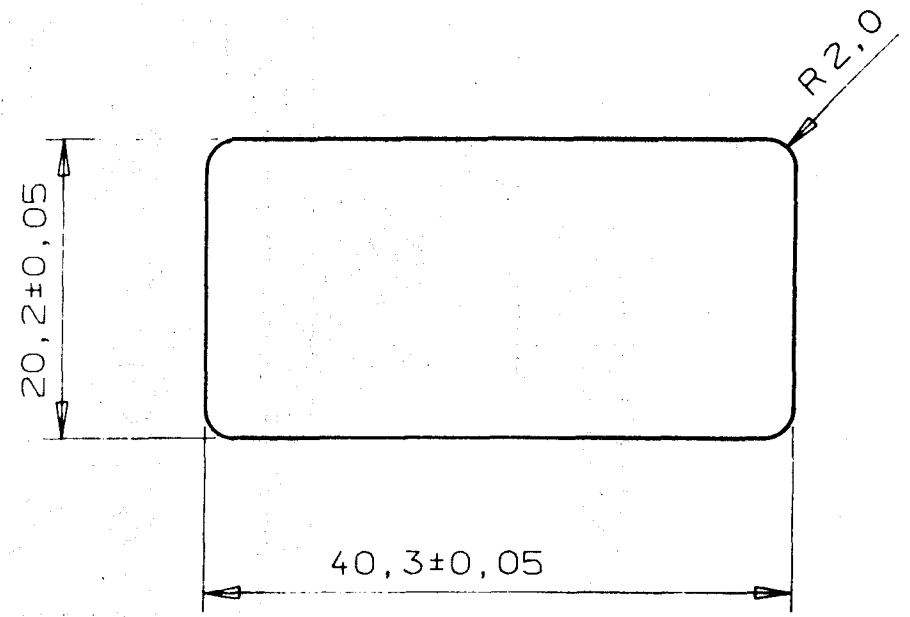

RIGHT SIDE VIEW



BIORACK

DOCUMENT NO.

Rev. .
Date .
Page

Supersedes:

Type I

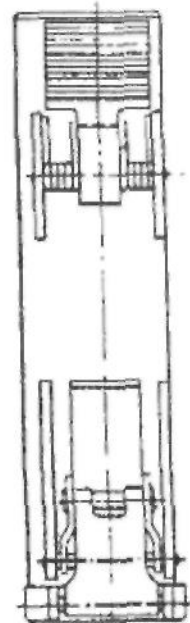
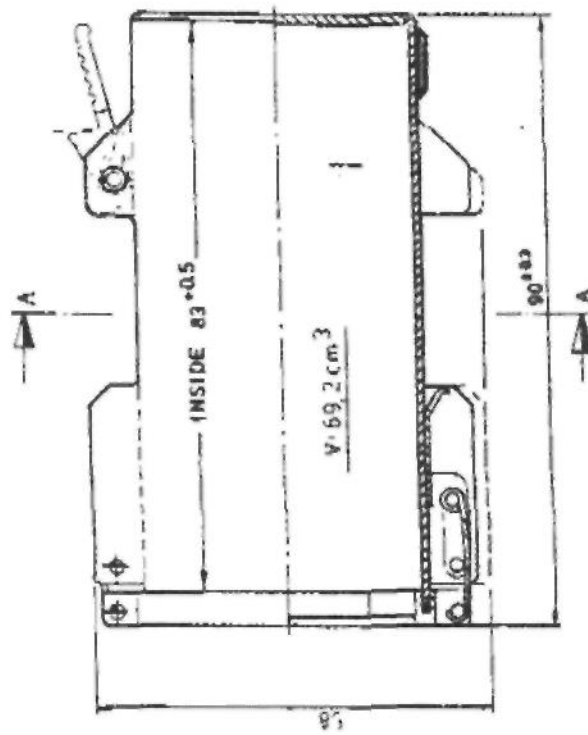
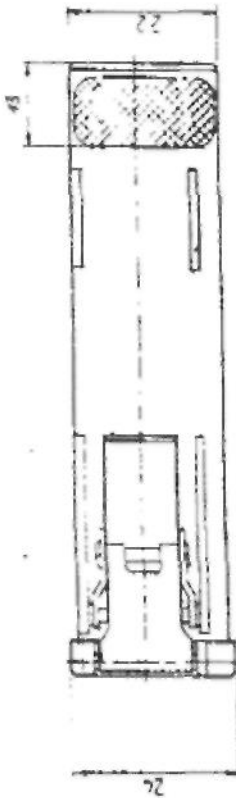
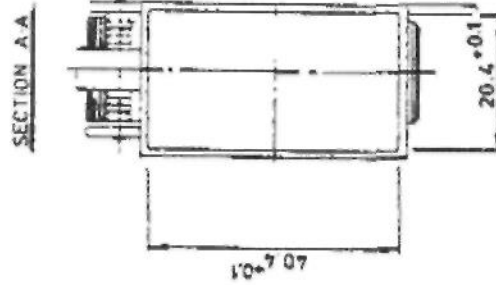

Bio - Kosmos 9 Free Space Unit

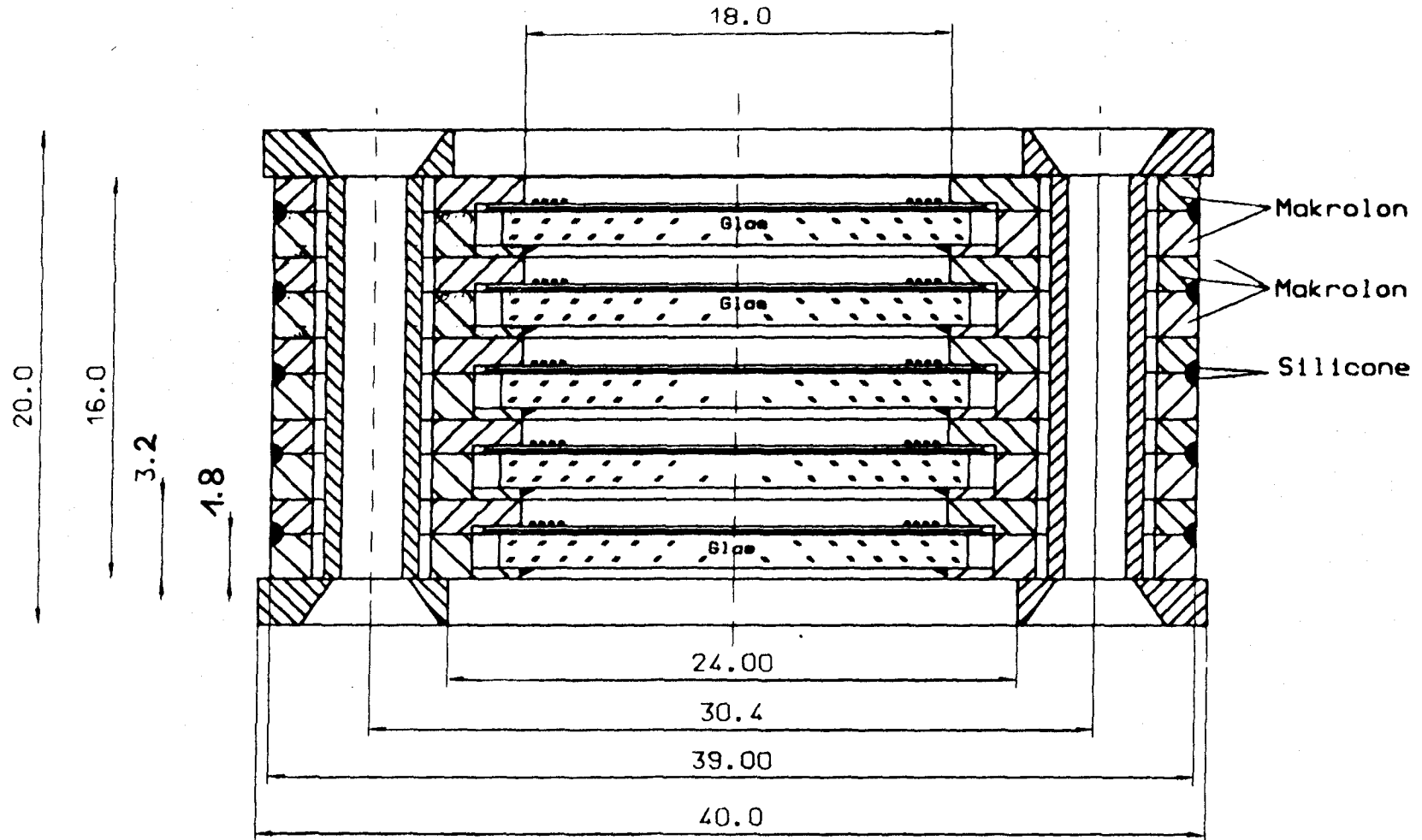

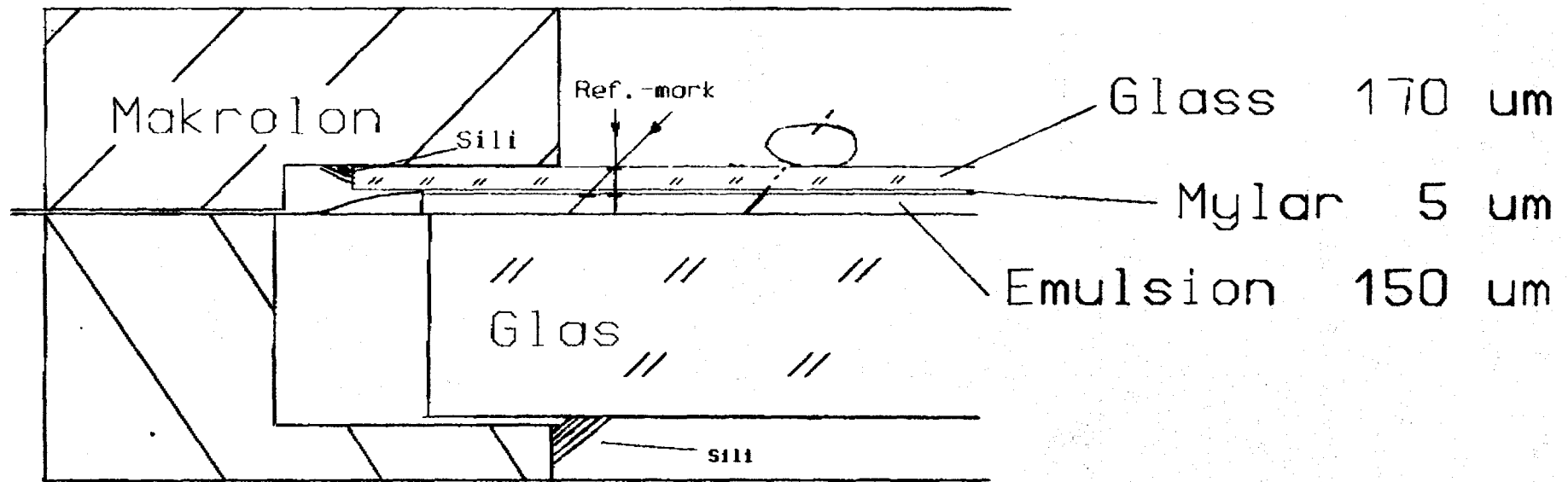

Biokosmos 9

Free Space Unit Type I

Compartment

EXACT DIMENSION
DEPENDENT ON THE
O-RING COMPRESSION

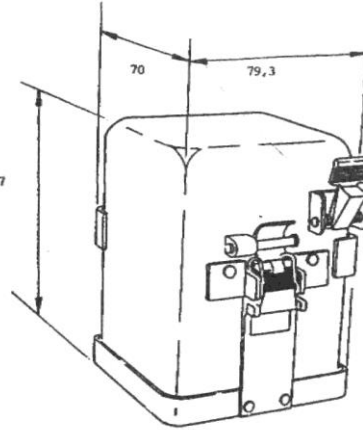
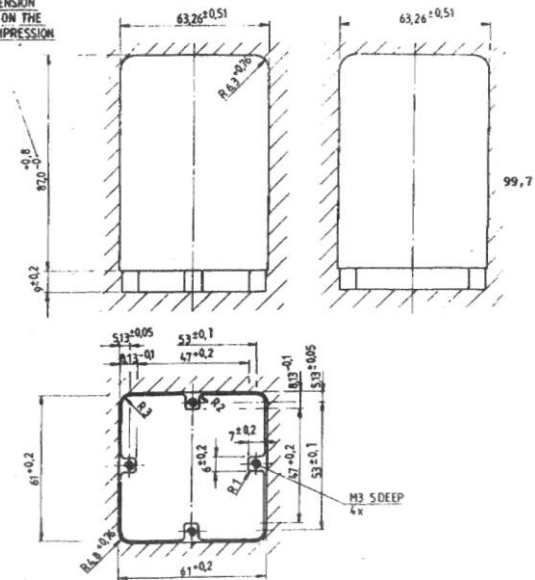

EXPERIMENT CONTAINER TYPE II

TYPE II CONTAINER INTERNAL DIMENSIONS in mm

BIOKOSMOS 9

Inside Unit Type II

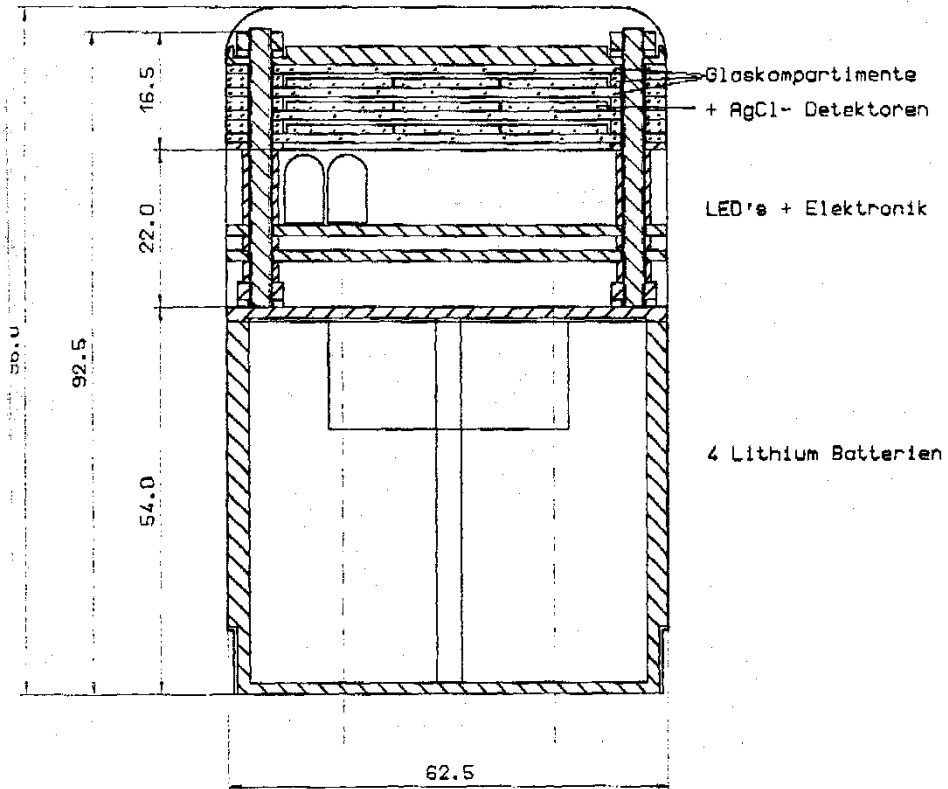

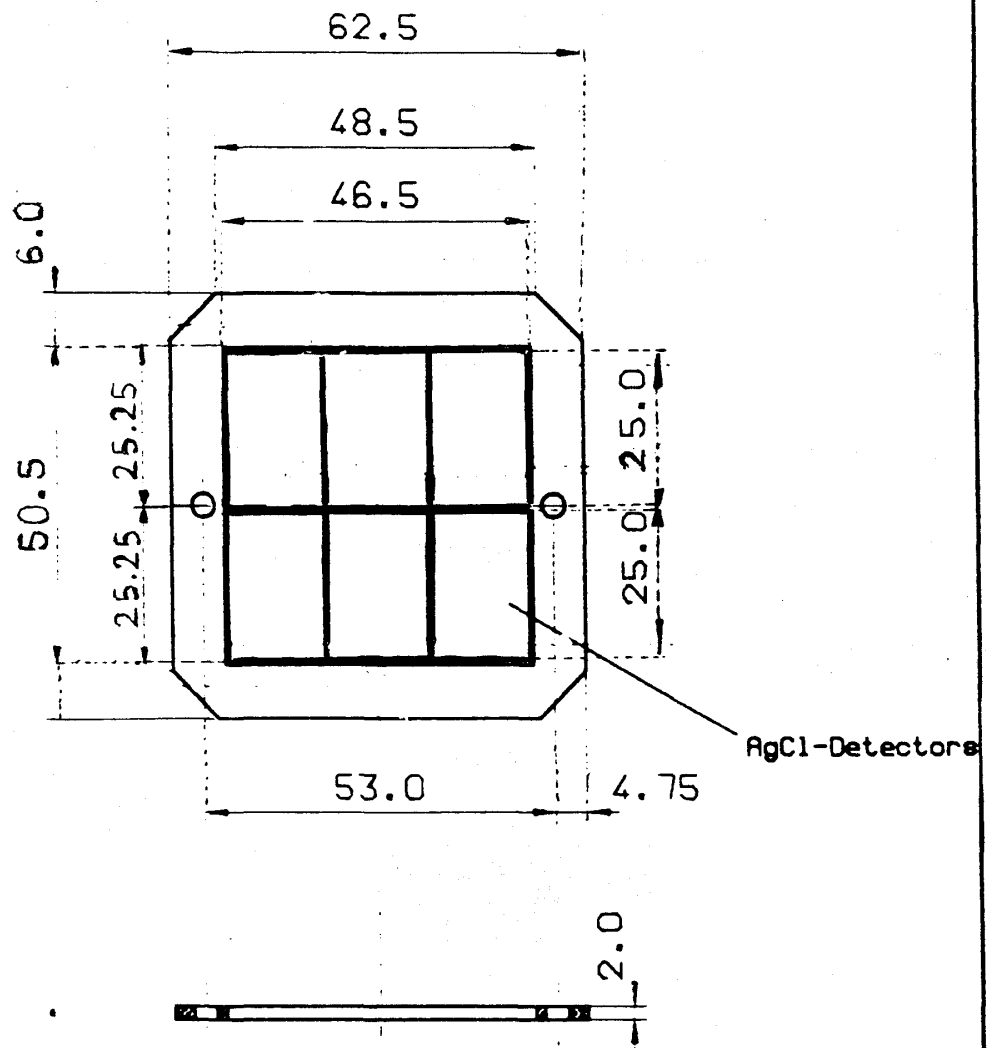

	Datum	Name	Institut für Kernphysik J.W.Goethe Universität Frankfurt/M
Gez.:	22.02.89	Raend	
Gepr.:			
Maßstab:	Biokosmos 9 Inside Unit Glass-Compartment. Centre-piece		Zeichnung Nr.:
1:1			BIOK0927.CAD

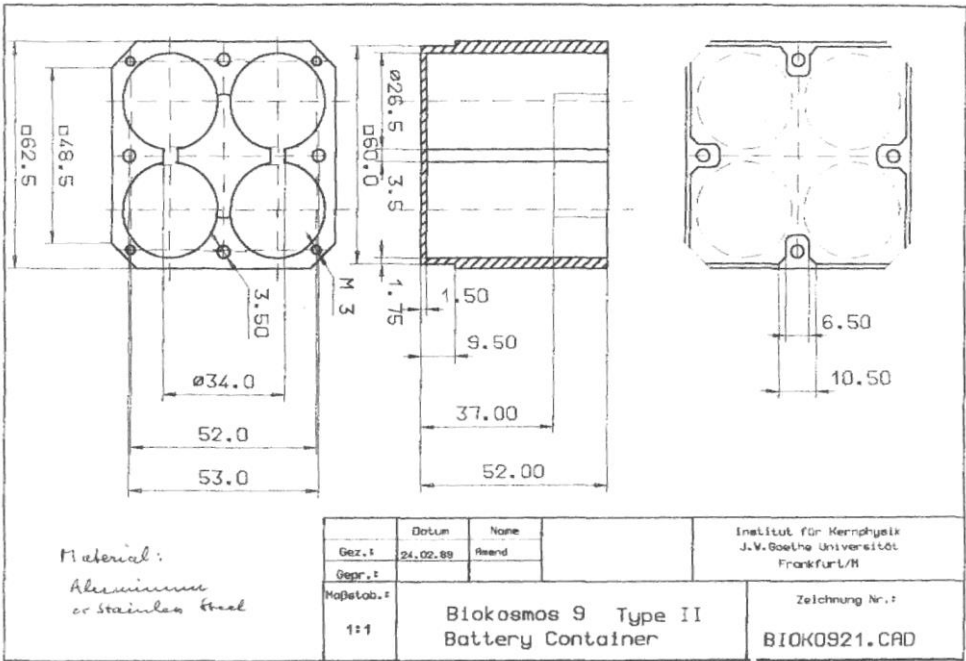

Material:
 Aluminium
 or stainless steel

	Datum	Name	Institut für Kernphysik J.W. Goethe Universität Frankfurt/M
Gez.:	24.02.89	Raend	
Gepr.:			
Maßstab:	1:1		Zeichnung Nr.:
Biokosmos 9 Type II Battery Container			BIOK0921.CAD



Lithium Sealed Cellpower

Zwei Lithiumsysteme, Zwei Bouformen
ISC Ge_ amprogramm

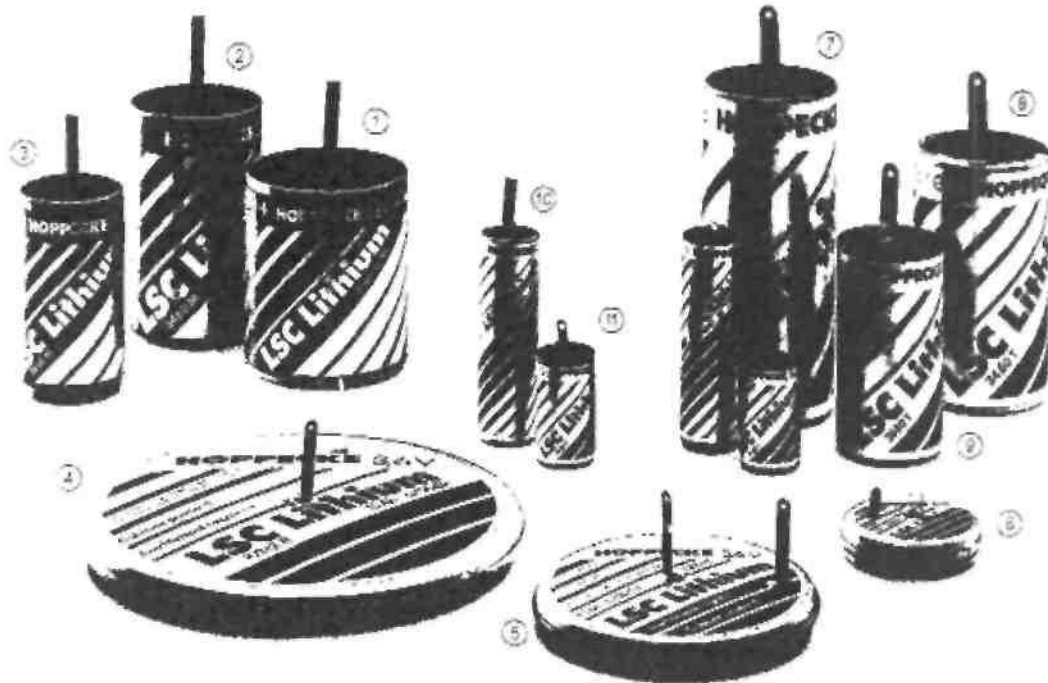

Lithium Sealed Cellpower System M Li/MnO₂

Type	Durchmesser in mm	Höhe in mm	Mittlere Entladespannung in Volt	Kapazität in Ah	Gewicht in Gramm	Erläuterungen
① LSC 4150 M	41	50	2,6	11	145	
② LSC 3460 M	34	60	2,8	10	130	»D« Size, IEC R 20, Mono
③ LSC 2650 M	26	50	2,8	45	60	»C« Size, IEC R 14, Baby

Lithium Sealed Cellpower System M Li/???

Type	Durchmesser in mm	Höhe in mm	Offene Klemmenspannung in Volt	Kapazität in An	Gewicht in Gramm	Erläuterungen
④ LSC 10212 Tf	102	12	3,6	15*	235	
⑤ LSC 6310 Tf	63,5	10	3,6	5,5*	75	
⑥ LSC 3210 Tf	32	10	3,6	1,4*	19	
⑦ LSC 3287 T	32	87	3,6	15	155	
⑧ LSC 3460 T	34	61	3,6	14	115	»D« Size, IEC R20, Mono
⑨ LSC 2650 T	26	50	3,6	5	56	»C«r Size, IEC R 14, Boby
⑩ LSC 1450 T	14,5	50	3,6	1,5	21	»AA« Size, IEC R 6, Mignon
(11) LSC 1425 T	14,5	25	3,6	0,6	11	»1/2AA« Size, 1/2 Mignon

Kapazitätswerte beziehen sich auf 20stündige Entladung, *100stündige Entladung



CHR-MICHELSSEN INSTITUTE
Dept.of Science and Technology

MATERIAL PART LIST

Doc.No:

Issue:

Date: 20. th. March

Sheet: 1

1987

Project:
AG F Gas Storage Module

DRAWING NO:	TRADE NAME:	MANUFACTURER:	MATERIAL:	CHEMICAL COMPOSITION:	USE AND LOCATION:	REMARK:	Itm. No.
Pos: 1 866118-	Aluminium	General Aerospace Material Corporation Brussel ,Belgium	6061-T6- 00A-250/11	Si=0.4-0,8; Fe=0,7; Zn=0,25; Cu=0,15-0,40; Mn=0,15; Mg=0,8-1,2; Cr=0,04-0,35; Ti=0,15; Other= 0,05-0.150	Cellekarmer		
Pos: 2 666118	- " -	- " -	- " -	- " -	Tilt stick		
Pos: 3 866118-	- " -	- " -	- " -	- " -	Pin		
Pos: 4 866118-	- " -	- " -	- " -	- " -	??t		
Pos: 7 866118-	- " -	- " -	- " -	- " -	Squeeze case		
Pos: 6 866118-	Stainless st.	Sandvik Steel Sandviken, Sveden	ASIM type 316 L W. no. 1.4436	C=0,03; Si=0,6; Mn= 1,7; P=0,03; S=0,03; Cr=17,5 Ni=13,5; Mo=2,7	Case		
Pos: 8 866118-	- " -	- " -	- " -	- " -	Axle tap		

BIORACK INCUBATOR FOR MIR

W. Jansen

Moscow, July 1989

BIORACK incubator for MIR

On October 26, 1988, a final presentation was given at ESTEC on a BIORACK incubator design for use on the MIR station. This study had been performed by the following companies: MATRA (France), Alcatel Bell (Belgium) and Dornier (FR Germany).

The BIORACK incubator was previously designed to the specific interfaces of a Spacelab Single Experiment Rack. The MIR adaptation study addressed in particular:

1. The aspect of transport of the incubator to MIR by a PROGRESS carrier, and the associated problems of its mechanical launch environment.
2. The installation of the incubator into and removal from MIR by cosmonauts.
3. The different thermal (cooling) and electrical interfaces provided by MIR with respect to Spacelab.

A maximum commonality with already developed hardware was aimed at.

The final report of this study addresses in detail the following aspects:

1. Study of the incubator container.
2. Structural design and analysis.
3. Power supply.
4. Thermal design and analysis.
5. Data recording and storage system.
6. Preliminary test plan for the MIR incubator.
7. Planning aspects.
8. Cost aspects.
9. MIR interfaces which require further clarification.

This handout summarises a few key points for discussion.

INCUBATOR CONTAINER DESIGN

1) General requirements

The design of container for incubator shall meet at the same time transport and mission requirements.

Functions of protection are

- ground operations and handling
- transport and orbit phases by Progress
- mission operation in the Mir station.

During mission operations the container shall provide

- mechanical interface attachment in the Mir station
- autonomous air cooling system with inlet and outlet for air flow
- general facility for Experimenter team :
 - access to the electrical connector interface
 - access to the Command and Control Panel (CMP)
 - access to the tray, centrifuges and experiment containers.

2) Mechanical presentation (Refer to fig. (2.2)₁ and (2.2)₂)

A study of specific container has been necessary.

It is composed of three parts a front cover, a middle part and a back cover.

In the middle part internal housing is necessary for channelling air around Dornier electronics. Inside this envelop on a specific braket two Artus fans are implemented for sucking air from BTM electronic compartment. On the middle part are also implemented :

- four quick fixations for each cover
- four handles for handling in ground operations
- four attachment fittings with shock absorbers for fitting container during launch and orbit phases by Progress.

In the Mir station front and rear covers are removed and unit is fixed with VELCRO Tape accomodated on the outside of its internal back housing. In addition two sets of belts are securing this position for operating mode in the Mir station. (Refer to fig. (2.2)₂)

CONTAINER (external shock absorbers)

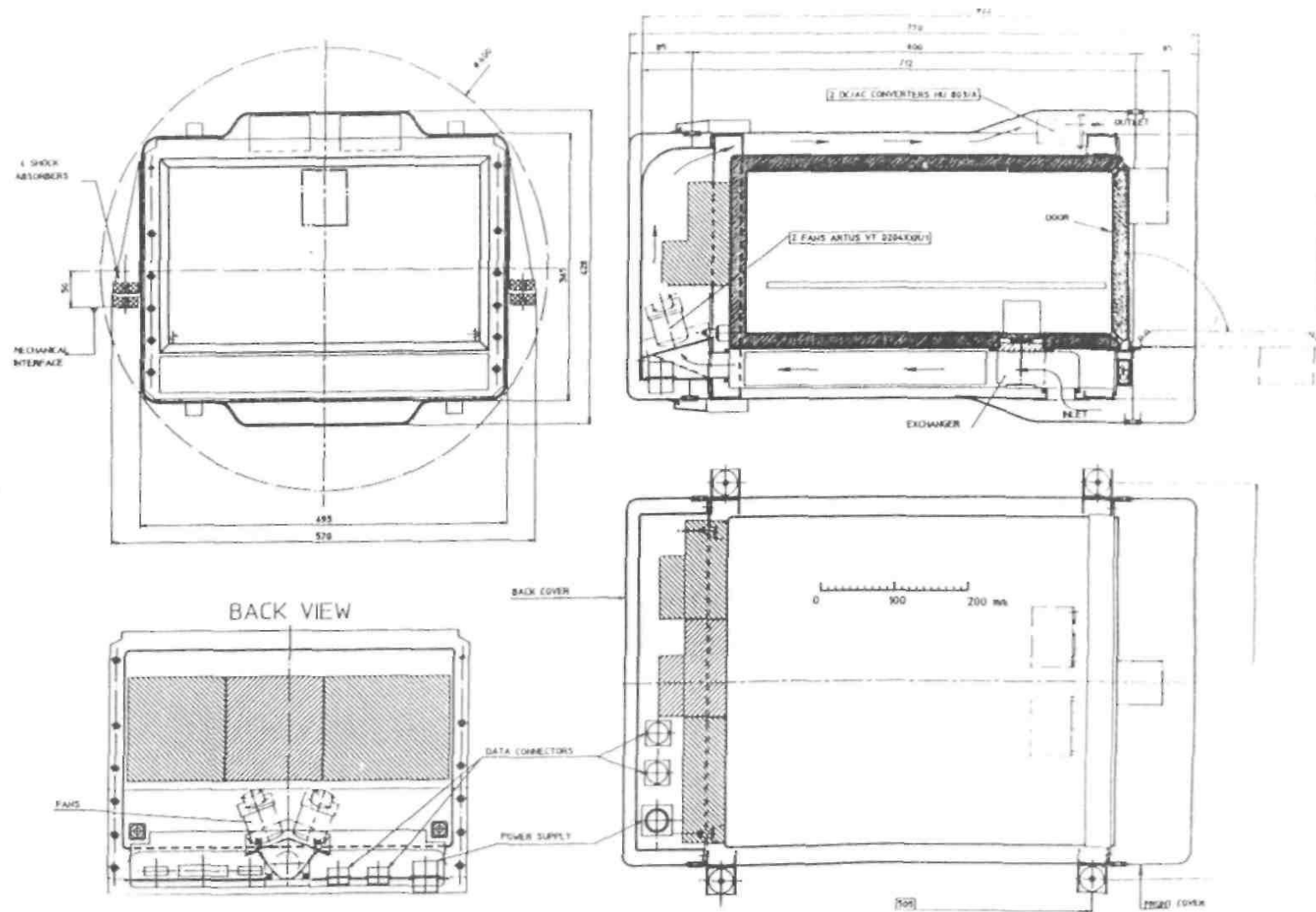

CONTAINER - FIG (2.2)1

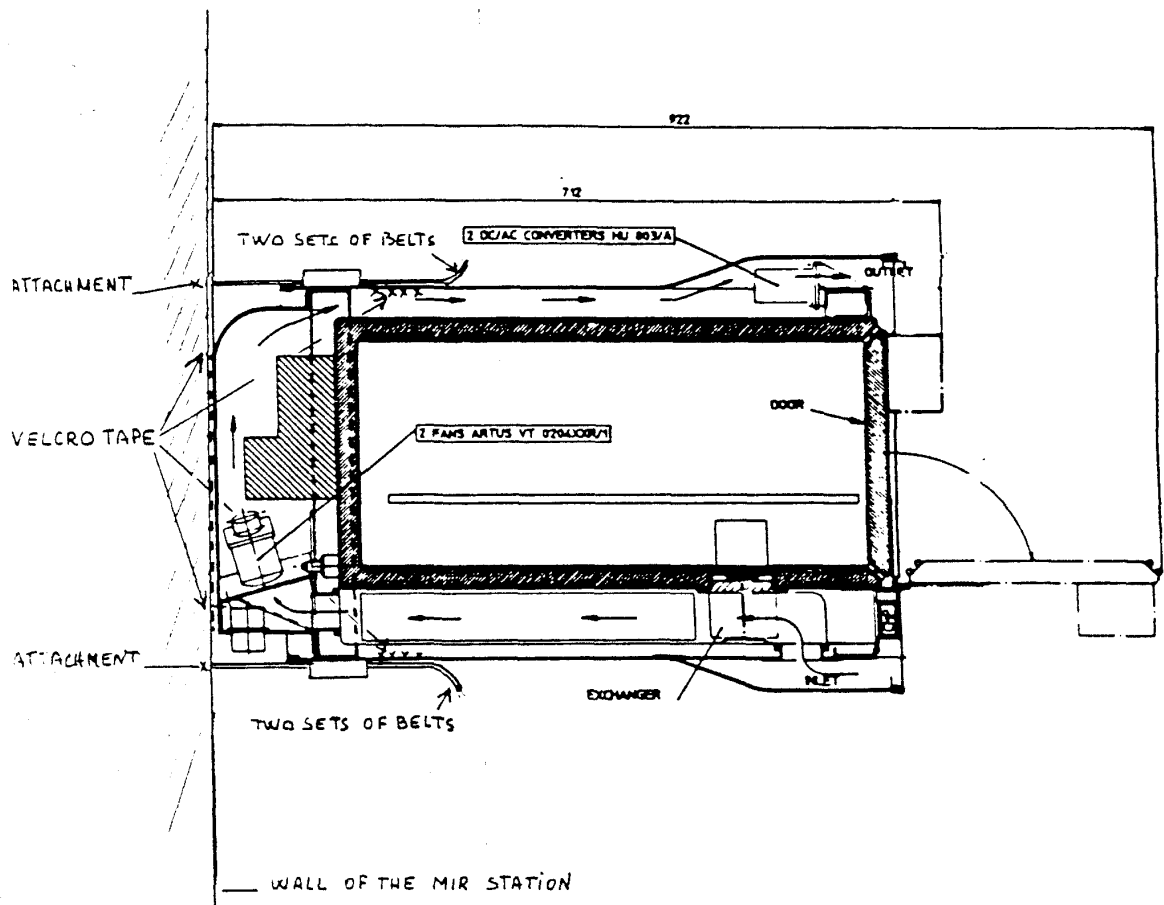

INCUBATOR IN OPERATING MODE
 Fig. (2.2)₂

The container is composed in its middle part of a rectangular cross section (494 x 365 mm) made in aluminium alloy. Two metallic frames are fitted at each end. They are made with rectangular cross section post: in aluminium alloy.

The front frame is receiving the front panel of incubator when this one is installed inside the container.

The back frame supports incubator by means of a new "MPE structure" and its spigots. It also supports internal envelop which is used for channelling air on the back wall of incubator.

The bottom of this internal envelop is composed by metallic housing which assume mechanical interface with air outlet of BTM electronic compartment. Its upper face is composed of a specific braket where are settled two Artus fans. The air flow output cross through rear and upper walls of incubator and before its output it cools the two DC/AC converters used to supply the fans. The middle part of container has two bulges for inlet and outlet of the air flow when front and rear covers are removed.

On the outside, the two frames are backing the middle part for attachment fitting with shocks absorber.

The middle part of the container is closed by two covers which are made in aluminium alloy sheet.

Each cover is fitted on the middle part by means of four quick attachments. Water tight is assumed on each part by flat gaskets.

Covers assure protections of the incubator during handling and transport they are removed for operating mode in the Mir station.

Autonomous air cooling system is provided by the shape of the container two Artus fans and their DC/AC converters. Motor fans are sucking air from inlet through BTM electronic and Peltier elements. Then the air flow is delivered from outputs of motor fans to outlet through Dornier electronics (back wall) and DC/AC converters fitted on the upper area of the container. The two DC/AC Artus converters are implemented in the upper bulge of the container near the outlet of the air flow. They are fitted on a specific braket with attachment to the front frame.

Accommodation of Artus fans and converters are dimensioned for providing to incubator an air flow of 20 kg/h and a differential pressure more than 1 millibar. (Refer to Fig. 2.4).

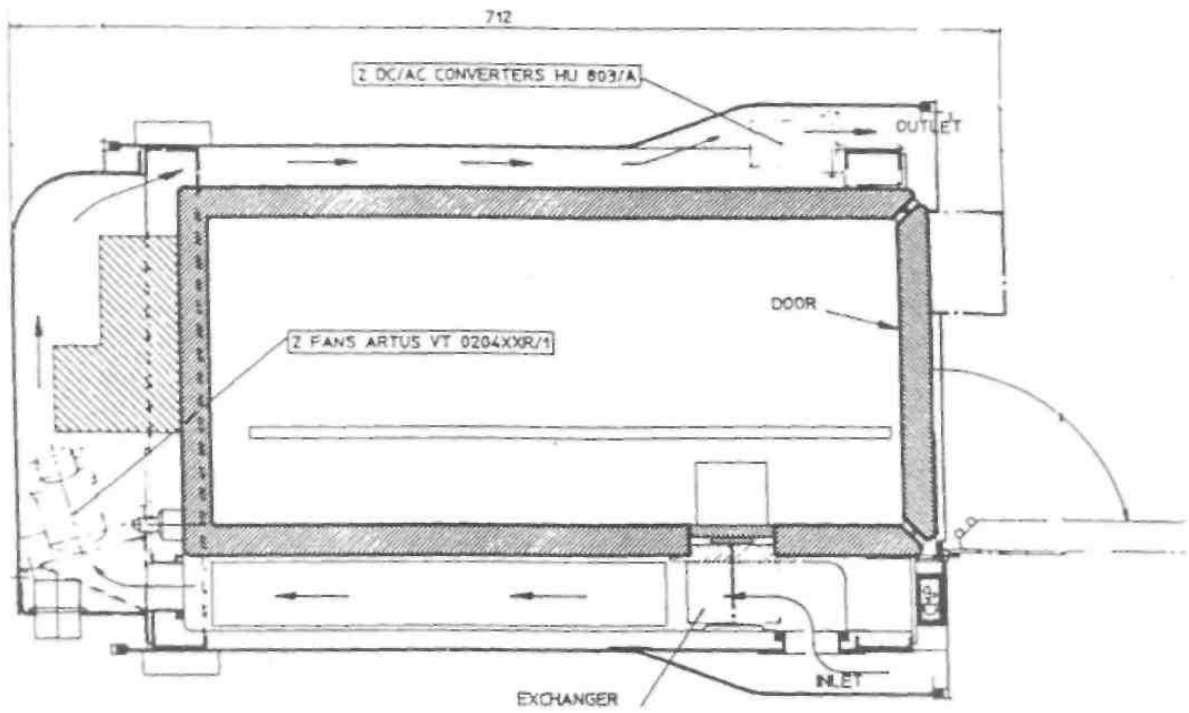

(FRONT AND REAR COVERS REMOVED)
INCUBATOR IN OPERATING MODE WITH
AUTONOMOUS AIR COOLING SYSTEM

FIG. 2.4.

Electrical aspect

Accommodation of the container around the incubator and the implementation of internal housing on its back wall for efficiency of air cooling is not accordance with an easy access to its interface connectors. MATRA ask to remove the three connectors on the bottom of the internal cover.

During handling and transport external back cover assumes a protection of connectors.

Implementation of an additional connector on this area is also possible for

????????????????

????????????????

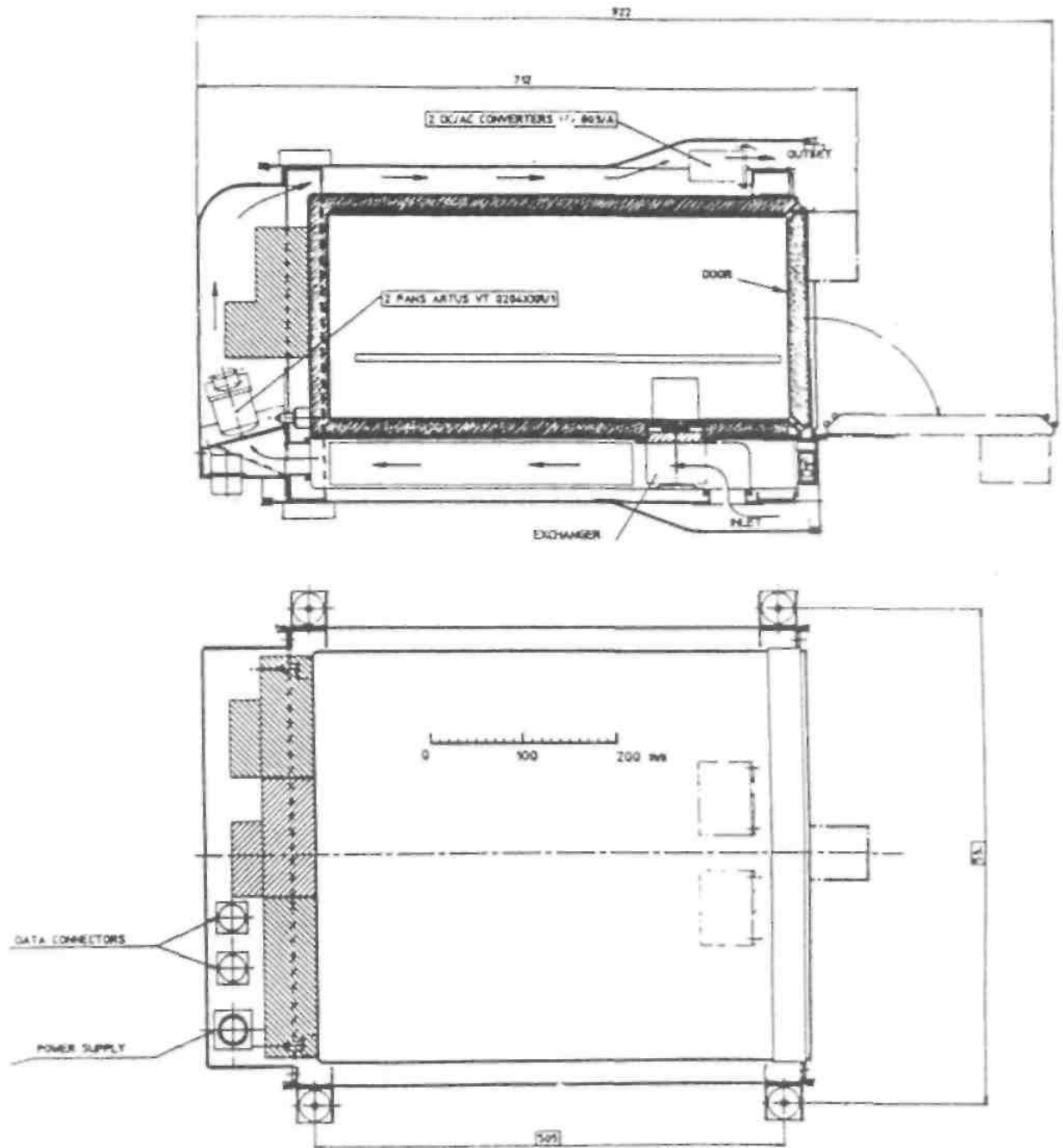

FIG. 2.5

1 - HARDWARE COMPATIBILITY WITH THE MIR DC POWER REQUIREMENTS

The DC power supply is 27 V + 7 V/- 4 V. The following table give the conclusions.

DC power supply	INCUBATOR		AIR COOLING SYSTEM	DATA SYSTEMS (1)	
	BTM Electronic	DORNIER Electronics		SFIM FLIGHT RECORDER (option 1)	CIMPAC BC 22 (option 2)
Overvoltage (34 V)	OK	OK	No (until 29 V)	No until 32.2 V	No (2)
Undervoltage (23 V)	OK	OK	OK	OK	NO (2)

(1) Data Systems : Option (1) or Option (2) are proposed.

(2) Refer to power budget for details (paragraph 2.3).

2. - POWER BUDGET

2.1 - Forward

The power consumption is calculated here after from the incubator in Spacelab conditions, then are added the needs of the Mir hardwares. The results are given for each data system option for activation and steady states modes.

2.2 - Option (1) Power budget

2.2.1 - Activation phase

MODE	INCUBATOR/C SPACELAB CONDITIONS	AIR COOLING SYSTEM	SFIM DATA SYSTEM	TOTAL POWER CONSUMPTION
Activation phase :	Watts	(W)	(W)	(W)
- Heating mode Ta < 36°C	90	29	60	179
- Cooling mode Ta > 36°C	92	29	60	181

For the option (1) the max power is 181 watts.

2.2.2. - Steady state centrifuges OFF

MODE	INCUBATOR (1) S.L CONDITIONS (Watts)	CENTRIFUGES ON (W)	AIR COOLING SYSTEM (W)	SFIM DATA SYSTEM (W)	TOTAL OF POWER (W)
Steady State Ta = 5°C Centrif. OFF	76	NA	29	60	165
Steady State Ta = 30°C	28	NA	29	60	117
Steady State Ta = 40°C _i	26 ⁽²⁾	NA	29	60	119

(1) Results for Incubators B and C

(2) + 4 watts in Mir conditions

??? Option ??) power budget

??? Activation phase

MODE	INCUBATOR IN Spacelab Condition (WATTS)	AIR COOLING SYSTEM (W)	DATA SYSTEM CIMPAC BC 22 (W)	TOTAL Power consumptio (W)
Activation phase Cooling mode Ta > 36°C	92	29	80 (1)	201

(1) The CIMPAC SC 22 chassis is powered by an AC power module of which the maximum capability is 160 watts.
The nominal power is 10 WATTS by slot, so for eight slots an average power of 80 watts.

Tacking in account an efficiency of 75 % the converter powering the 80 watts of the power module will be of 106 watts.
Two possibilities :

a.) The converter ⁽¹⁾ is a DC/DC converter replacing the AC power module of the CIMPAC BC 22.
The power will be for Activation phase :

$$92 + 29 + 106 = 227 \text{ watts}$$

(1) This possibility is existing for serie orders.

? The converter is a DC/AC converter which is supplying the AC power module and the power consumption for activation will be :

$$92 + 29 + 80 + 106 = 307 \text{ watts}$$

This last result is the worse case but also the lower cost. Calculation in steady state are made with this assumption.

Remark : A relevant choice of converter should permit to meet the Mir DC power requirement of 28 V + 7 V - 4 V

2.3.2 - Steady state centrifuges OFF

MODE	INCUBATOR SL CONDITIONS Watts	CENTRIFUGES ON (W)	AIR COOLING SYSTEM (W)	CIMPAC BC 22 DATA SYSTEM (W)	TOTAL OF POWER (W)
Steady state Ta = 5 °C	76	NA	29	186	291
Steady state Ta = 30°C	28	NA	29	186	243
Steady state Ta = 40°C	26 ⁽¹⁾	NA	29	186	245

(1) + 4 watts in Mir conditions

2.3.3 - Steady state centrifuges ON

MODE	INCUBATOR IN S/L CONDITIONS (Watts)	CENTRIFUGES ON (W)	AIR COOLING SYSTEM (W)	CIMPAC BC 22 DATA SYSTEM (W)	TOTAL POWER (W)
Steady state Ta = 5°C	64	20	29	186	299
Steady state Ta = 30°C	22	20	29	186	257
Steady state Ta = 40°C	20 ⁽¹⁾	20	29	186	259

(1) + 4 watts in Mir Condition.

Conclusions :

With a DC/AC converter supplying the AC power module the maximum power consumption observed in the same modes that the number (1) Option.

- Activation phase and cooling mode (Ta > Tset) :

$$P = 307 \text{ watts.}$$

- Steady state, centrifuges ON and T = 5°C

$$P = 299 \text{ watts.}$$

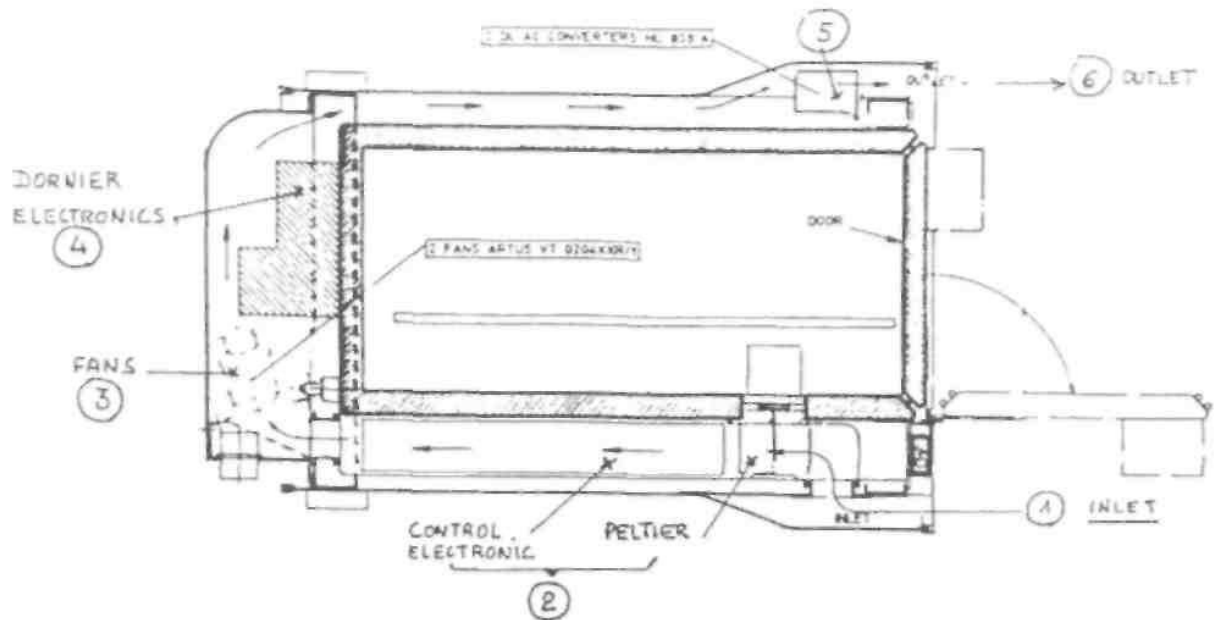

RECAPITULATION OF TEMPERATURE PREDICTIONS

	①	②	③	④	⑤	⑥
Modes	Temperature AIR INPUT	PELTIER and Control Elect.	FANS	DORNIER Electronics	DC/AC converter	Temperature AIR OUTPUT
Act.Ph	5°C	5.7°C	4°C	1.5°C	1.3°C	17.5°C
S.sc.C OFF	5°C	5.4°C	4°C	1.5°C	1.3°C	17.2°C _c
S.st.C ON	5°C	4.4°C	4°C	2.5°C	1.3°C	17.2°C
Act.Ph	30°C	5.7°C	4°C	1.5°C	1.3°C	42.5°C
S.sc.C OFF	30°C	2 °C	4°C	1.5°C	1.3°C	38.8°C
S.sc.C ON	30°C	1.58°C	4°C	2.5°C	1.3°C	39.38°C
Act.Ph	40°C	14.8°C	4°C	1.5°C	1.3°C	61.6°C
S.sc.C OFF	40°C	5.4°C	4°C	1.5°C	1.3°C	52.3°C
S.sc.C ON	40°C	4.3°C	4°C	2.5°C	1.3°C	52.1°C

Act.Ph : Activation Phase

S.sc.C OFF : Steady State Centrifuges OFF

S.st.C ON : Steady State Centrifuges ON

PLANNING OF THE C/D PHASE

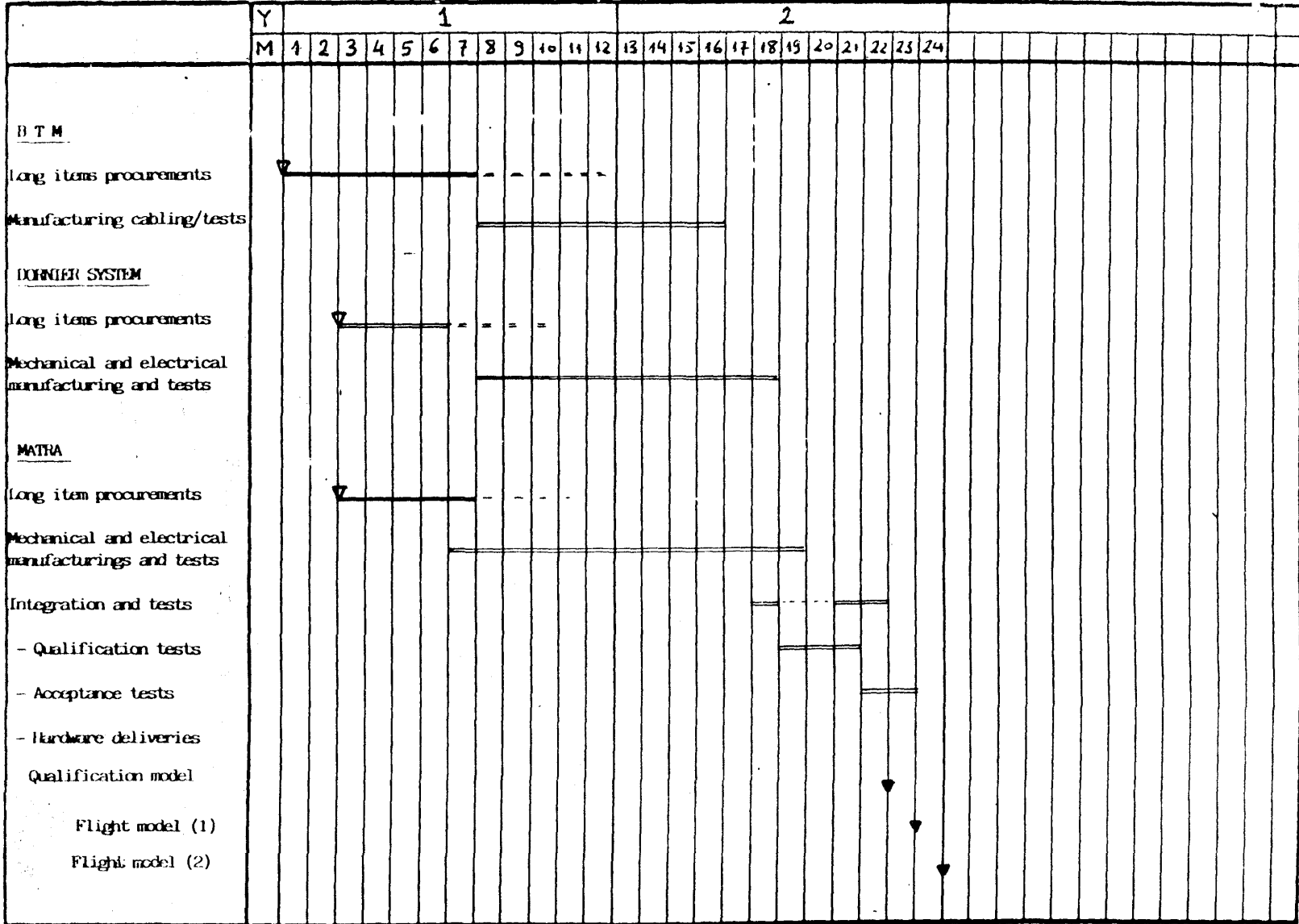

ESA/IBMP SPACE BIOLOGY COORERATION

COSMOS/BIOCOSMOS MISSIONS

- o **BIOCOSMOS SINGLE EXPERIMENTS (1989)**
- o **MINI GRAVITATIONAL BIOLOGY FACILITY EXPERIMENTS (not earlier than 1990).**

MIR SPACE STATION MISSIONS

- o **MIR BIORACK EXPERIMENTS (1990 and onwards).**

Dick Mesland

ESA/IBMP SPACE BIOLOGY COOPERATION

Page 1

BIOCOSMOS SINGLE EXPERIMENTS **(1989 and onwards)**

1. Exposure Experiments

1.1. Hardware

Stacks of sheets containing biological material and sheets of dosimetric material, to be fitted on Bio-cosmos exposure facilities.

1.2. General Science Objective

Effect of space vacuum and radiation on seeds, spores and biomolecules of different biological species.

1.2.1. Experiment Steps

- o Totally passive experiment**
- o Radiation and biological analysis after flight**

BIOCOSMOS SINGLE EXPERIMENTS
(continued)

2. Microgravity experiments

2.1. Hardware

- o Experiment- specific hardware is available now (slight modifications might be needed).
- o Experiments will be accommodated in Biorack standard experiment containers.
- o Experiments requiring electrical power will have their own batteries.
- o Experiment containers can be flown in standard Biorack Passive Thermal Control Units (PTCU's);
Temperatures: + 5°C (23 days), + 22° C (21 days)
+ 37° C (... days).
- o Experiment Containers can be transported to the launch site and from the landing site in PTCU's.
Temperatures: - 10° C, + 5°C, +10° C, + 22° C, + 37° C (tbc)
- o No IG control centrifuge
- o Identical experiment hardware for the synchronous ground control experiment

ESA/IBMP SPACE BIOLOGY COOPERATION

Page 3

BIOCOSMOS SINGLE EXPERIMENTS

(continued)

2.2. General Science Objective (1)

Effect of microgravity on cell proliferation

2.2.1. Experiment Steps

- o Incubate cells in flight
- o Analyse cells after flight
- o Compare growth on solid substrate with growth in suspension
- o Ultra-structural analysis: mitosis and meiosis
- o Cytoskeleton
- o Determine mutation rate
- o Continue and analyse growth after flight
- o Probe for particular cell product, or function, after flight

2.2.2. Biological specimen

- o Bacteria
- o Yeast cells
- o Chlamydomonas cells
- o Paramecium cells
- o Hybridomona cells
- o Leukemia cells
- o Embryonic cells

ESA/IBMP SPACE BIOLOGY COOPERATION

Page 4

BIOCOSMOS SINGLE EXPERIMENTS

(continued)

2.3. General Science Objective (2)

Effect of microgravity on developmental processes

2.3.1. Experiment Steps

- o Initiate development in flight
- o Analyse development after flight
- o Microscopic and ultrastructural analysis
- o Continue and analyse development after flight.

2.3 .2. Biological Systems

- o Bacterial sporulation, conjugation
- o Yeast sporulation, mating
- o Dictyostelium aggregation, sporulation
- o Chlamydomonas mating
- o Xenopus egg fertilization, development
- o Drosophila oogenesis, development, aging
- o Artemia development
- o Carausius development

BIOCOSMOS SINGLE EXPERIMENTS
(continued)

2.4. General Science Objective (3)

Effect of microgravity on in vitro molecular processes

2.4.1. Experiment Steps

- o Initiate and stop reaction in flight (or monitor in flight)
- o Analyse reaction after flight

2.4.2. Biomolecular System

- o DNA replication
- o Microtubule assembly / disassembly
- o Microfilament assembly / disassembly
- o Enzyme reactions (kinases, phosphorylases)
- o Protein synthesis

ESA/IBMP SPACE BIOLOGY COOPERATION

Page 6

BIOCOSMOS SINGLE EXPERIMENTS (con tinued)

2.5 GENERAL SCIENCE OBJECTIVE (4)

Animal physiological studies

Participation by ESA?

MINI GRAVITATIONAL BIOLOGY FACILITY EXPERIMENTS
(not earlier than 1990)

1. General Science Objective

Effect of microgravity on growth and development of microorganisms, small animals and small plants

2. Experiment Types

- o Proliferation, differentiation and mating of protozoa, fungi and algae**
- o Cytogenetic studies on microorganisms**
- o Oogenesis, fertilization and embryogenesis in small animals**
- o Ageing in small animals**
- o Germination, growth, development and seed formation in small plants**

MINI GRAVITATIONAL BIOLOGY FACILITY EXPERIMENTS
(continued)

3. Experiment Steps

- o Initiation of experient in flight (watering, mixing, injection of some component)
- o In flight monitoring of video images atmospheric parameters temperature experiment specific data
- o Some in flight fixation
- o Post flight analysis of experiments
- o Post flight continuation of some experiments

4. Experiment Example

The genotypic control of graviresponse, cell polarity and morphological development of Arabidopsis thaliana in a microgravity environment.
(Maher/Briarty)

- o Fly seed of wild type and two agravitropic mutants aux- 1 and DWF
- o Water seeds in flight
- o Monitor growth of roots and hypocotyls o Fix plants at predetermined times
- o Post flight morphological and ultrastructural analysis
- o Comparative study of wild type, mutant and ground control plants.

MIR BIORACK EXPERIMENTS
(1990 and onwards)

1. Minimal Biorack Configuration

- o 1 Cooler/Freezer (from MIR or ESA)
- o 1 Incubator 37° C
Includes 2 control centrifuges
- o 2 Passive Thermal Control Units (PTCU's)
- 10^u C, + 5^u C for transport purposes
- o Additional: Workbench (from MIR)
Inflatable glove box
Microscope
- o Identical hardware for the synchronous ground control experiment and for crew training purposes.

MIR BIORACK EXPERIMENTS
(continued)

2. Operations scenario

- o Biorack units delivered by Progress Tanker and installed by crew.
- o Experiment sets, in standard Biorack containers, prepared close at launch site
- o Experiment sets loaded in PTCU's
- o PTCU's delivered to MIR by Progress Tanker or Soyuz
- o Experiments conducted according to flight plan
- o Experiment sets loaded in PTCU's
- o PTCU's delivered to ground by Soyuz
- o Experiment sets handed over to Pi's
- o And so on

MIR BIORACK EXPERIMENTS

(continued)

3. Experiments Requiring 37° C (step 1)

3.1. General Science Objectives

Effect of microgravity on:

- o immunological processes**
 - o haemato poietic processes**
 - o bacterial proliferation**
- at the cellular level.**

3.1.1. Experiment Types

- o Experiments with isolated cells of the immune system (B lymphocytes, immature T cells, cytotoxic T cells, T helper and T suppressor cells)**
- o Experiments with blood cells taken from the crew in flight**
- o Experiments with isolated bone marrow cells**
- o Study maturation and function of different cell types**
- o Study bacterial proliferation and effectiveness of ant idiotics**

MIR BIORACK EXPERIMENTS
(continued)

4. Experiments Requiring 22° C (step 2)

4.1. Minimal Biorack Configuration

As 1., but additional 22° C incubator

4.2 General Science Objectives

- o Effect of microgravity on growth and development of microorganisms, small animals and small plants
- o Effect of microgravity on biomolecular processes

MIR BIORACK EXPERIMENTS
(continued)

5. Experiment Types

- o Proliferation, differentiation and mating of protozoa, fungi and algae**
- o Cytogenetic studies on microorganisms**
- o Oogenesis, fertilization, early development and embryogenesis in small animals**
- o Ageing in animals with short duration life cycles**
- o Germination, growth and development in small plants**
- o In vitro biomolecular reactions with i.a. DNA/RNA, cytoskeletal proteins, enzymes etc.**

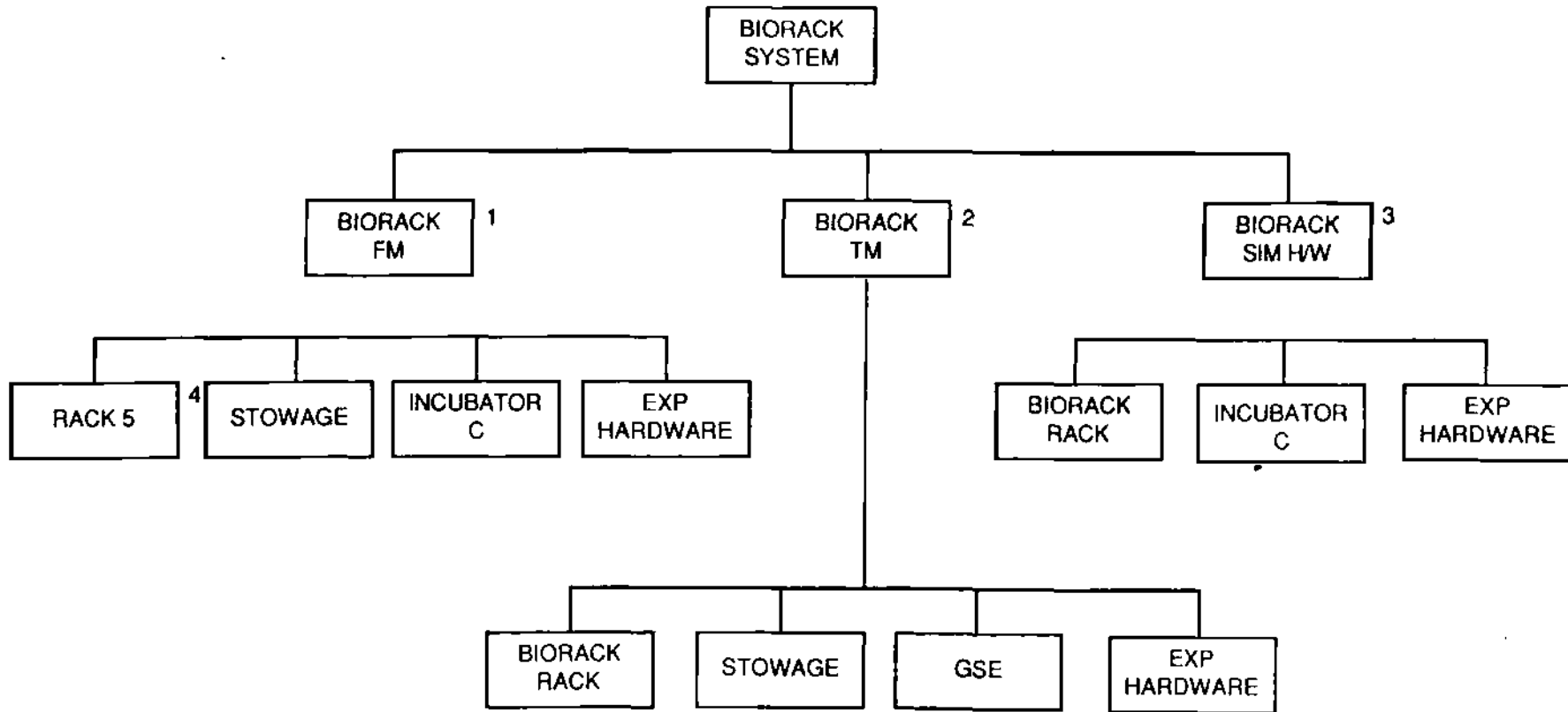

BIORACK SYSTEM

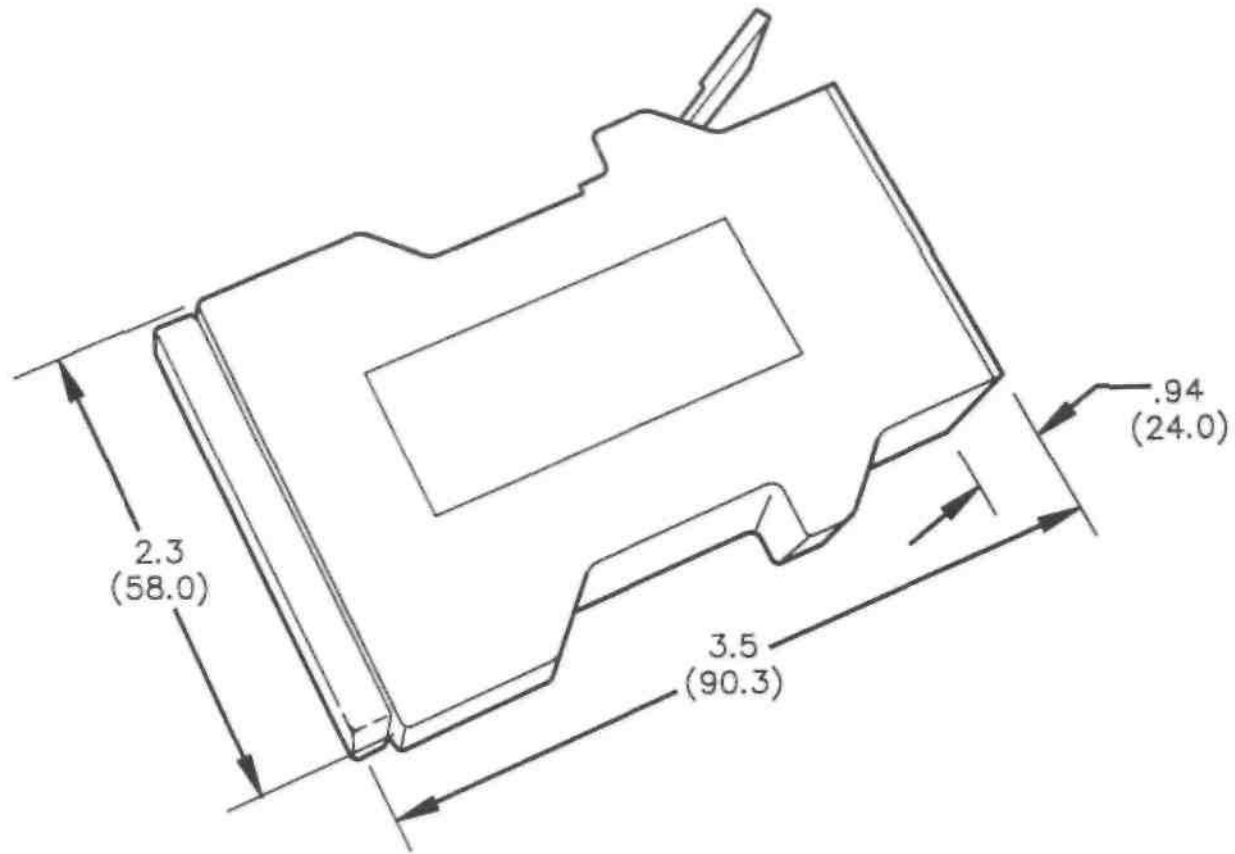

NOTE:
ALL DIMENSIONS ARE IN INCHES(MM)
EXPERIMENT CONTAINER TYPE I

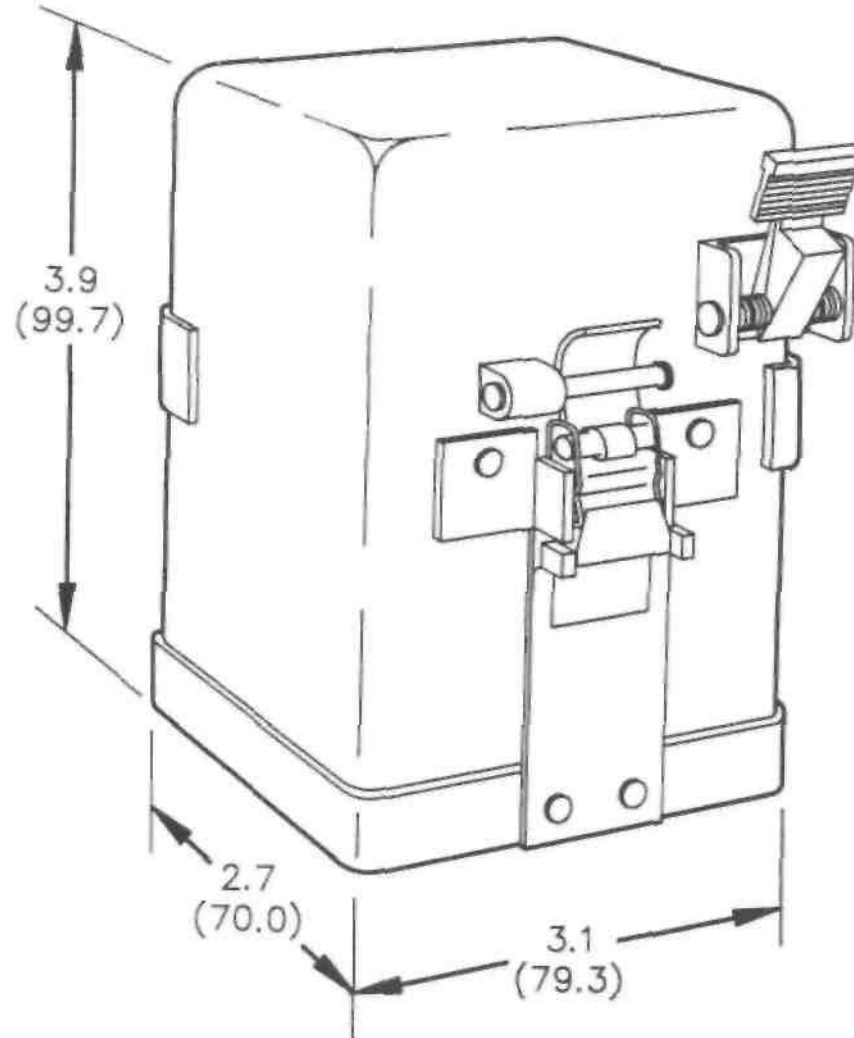

NOTE:
ALL DIMENSIONS ARE IN INCHES(MM)
EXPERIMENT CONTAINER TYPE II

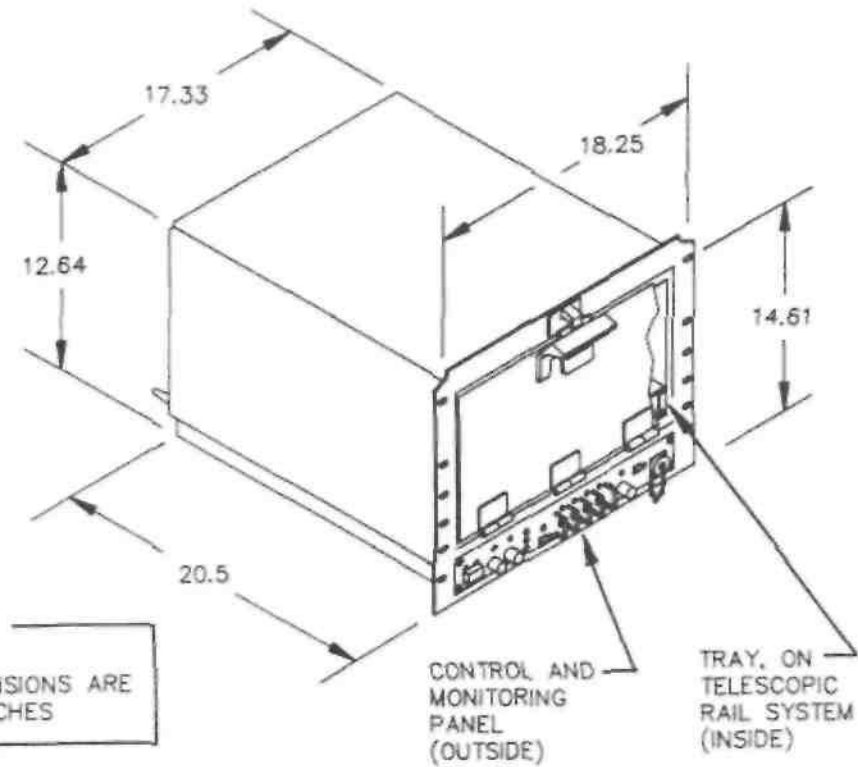
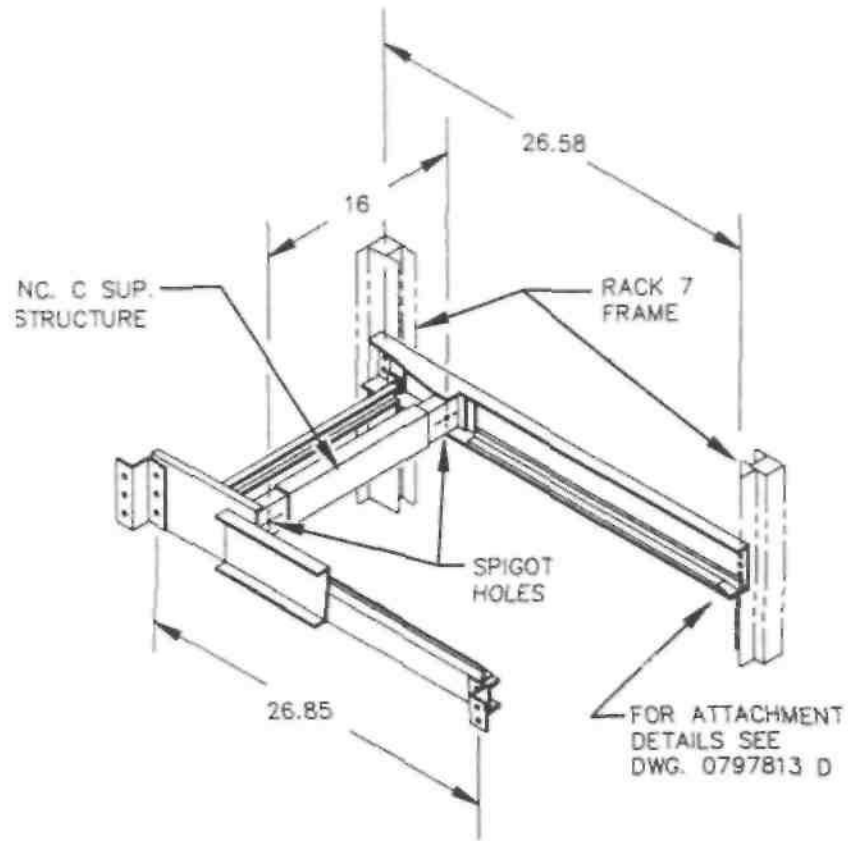

NOTE:
DIMENSIONS ARE IN INCHES

BIORACK INCUBATOR C INTERFACE DEFINITION

ELECTRICAL POWER CONSUMPTION

BIORACK ATCU	POWER CONSUMPTION AT 30 °C			
	STEADY STATE		MAXIMUM	
	DC [W]	AC [VA]	DC [W]	AC [VA]
Rack 7 Incubator C Centrifuges 1&2	<60. <20.	- -	<95. <20.	- 0

NOTES:

- (1) The experiment container power of max. 6 W for each incubator has not been considered.
- (2) Above values are specified for an avionic air cooling temperature of 30 °C and an air supply of 20 kg/h for each incubator and 96 kg/h for the cooler/freezer. If the air temperature increased above 30 °C or the air supply is less than specified the required power will increase significantly.

THERMAL ACCOMMODATION SUMMARY

BIORACK ATCU	TOTAL DISSIP. HEAT [W]	AVIONICS AIR LOOP			CABIN AIR	
		MIN. COOLIN G [W]	MIN. FLOW RATE [KG/H]	TEMP. MIN/MAX [°C]	MIN. COOLIN G [W]	MIN. FLOW RATE [KG/H]
Rack 7 Inc. C only	110.	92.	20.	10./30.	N.A..	N.A

**BION-10
SCIENTIFIC DATA EXCHANGE**

**R. Demets
Moscow, December 3-4, 1991**



BION-10 SCIENTIFIC DATA EXCHANGE

Exchange of scientific data (historical overview)

BION-8(1987)

- Every publication a joint publication
(no longer applicable since Bion-9)
- All investigators appear as authors in every publication
(no longer applicable since Bion-9)
- Publications in USSR: Soviet investigators leading
(no longer applicable since Bion-9)
- Publications in the West: ESA investigators leading
(no longer applicable since Bion-9)



BION-10 SCIENTIFIC DATA EXCHANGE

Exchange of scientific data (historical overview continued)

BION-9(1989)

- Exchange of preliminary data 6 months after flight ("Madrid" meeting, April 1990)
- Final data exchange not later than 24 months after the flight (October 1991)
- After data exchange, investigators are free to publish (no longer applicable for Bion-10)



BION-10 SCIENTIFIC DATA EXCHANGE

Scientific data exchange for BION-10

Contents

	Data flow	Section
ESAPI	to/from USSR PI	1
PI	to Science journal	2
PI	to Financing organization	3
PI	to ESA, IBMP	4
ESA, IBMP	to PI	5



BION-10 SCIENTIFIC DATA EXCHANGE

SECTION 1

(Exchange of scientific data, PI versus PI)

- 1.1 For each experiment there will be an early (preliminary) data exchange, if necessary followed by a final data exchange, whereby PI's collaborating within one experiment present their respective findings as written reports.
- 1.2 The date of exchange of the preliminary results is fixed for all experiments at 6 months after the flight.
- 1.3 The date of exchange of the final results will be determined per experiment by the applicable PI's. This date will not be later than 24 months after the flight and its timing requires approval from ESA and IBMP.
- 1.4 Copies of preliminary and final data exchange reports shall duly be provided to ESA and IBMP.
- 1.5 Reprints of publications shall duly be exchanged between PI's.



BION-10 SCIENTIFIC DATA EXCHANGE

SECTION 2

Scientific publications

(PI versus science journal)

- 2.1 It is not allowed to publish results before a data exchange has taken place (see 1.1, 1.2 and 1.3).
- 2.2 Manuscripts will be exchanged between the collaborating PI's prior to submission for publication.
- 2.3 Manuscripts that contain unpublished science data from one counterpart-PI need the other counterpart's approval before they are submitted for publication.
- 2.4 The PI enjoys an exclusive right* to apply for publication of his results for a period of six months, starting from the presentation and exchange of these results (see 1.1, 1.2 and 1.3).

To be continued on the next page



BION-10 SCIENTIFIC DATA EXCHANGE

SECTION 2 (continued) Scientific publications (PI versus science journal)

- 2.5 Each publication shall include an acknowledgement of the services afforded by ESA and IBMP.
- 2.6 A copy of each scientific publication shall duly be provided to ESA and IBMP.
- 2.7 In the event the publications are protected by copyright, the PI shall request the scientific journal's publisher to offer ESA and IBMP a royalty-free right to reproduce and use such work, and to prepare derivative work of such copyrighted work for their own purposes.
- * ESA and IBMP will have the right to use the scientific data for support of their respective responsibilities. In this context, ESA and IBMP undertake not to infringe upon the PI's first publication rights which are established in accordance with paragraph 2.4



BION-10 SCIENTIFIC DATA EXCHANGE

SECTION 3

Reporting to financing organizations
(PI versus national funding agency)

- 3.1 If the PI is obliged to present his results to a financing organization prior to the dates of science data exchanges, a copy of this report will be sent to his counterpart-PI.



BION-10 SCIENTIFIC DATA EXCHANGE

SECTION 4

Reporting to ESA and IBMP
(PI versus ESA, PI versus IBMP)

- 4.1 Copies of preliminary and final data exchange reports shall duly be provided to ESA and IBMP (see 1.4).
- 4.2 Copies of all scientific publications shall duly be provided to ESA and IBMP (see 2.6).
- 4.3 Three years after the flight all scientific data, including those that had not been incorporated in publications, will be deposited with the data depositories of ESA and IBMP.



BION-10 SCIENTIFIC DATA EXCHANGE

SECTION 5

Data recorded by ESA and IBMP
(ESA versus PI, IBMP versus PI)

- 5.1 The PI will receive all applicable data recorded by ESA and/or IBMP during the mission (e.g. experiment temperature history, experiment house-keeping data, acceleration history) within 6 months after the flight.